

JVC®



DIGITAL VIDEO CAMERA

GR-DVX70

ENGLISH

Please visit our CyberCam Homepage on the World Wide Web and answer our Consumer Survey (in English only):

<http://www.jvc-victor.co.jp/english/index-e.html>

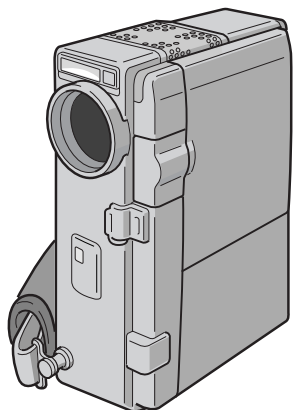

Mini **DV** PAL
DSC
DIGITAL
STILL CAMERA
TransP



INSTRUCTIONS

LYT0412-001A

EN

Dear Customer,

Thank you for purchasing this digital video camera. Before use, please read the safety information and precautions contained in the following pages to ensure safe use of this product.

Using This Instruction Manual

- All major sections and subsections are listed in the Table Of Contents (☞ pg. 6, 7).
- Notes appear after most subsections. Be sure to read these as well.
- Basic and advanced features/operation are separated for easier reference.

It is recommended that you . . .

- refer to the Index (☞ pgs. 99 – 106) and familiarize yourself with button locations, etc. before use.
- read thoroughly the Safety Precautions. They contain extremely important information regarding the safe use of this product.

You are recommended to carefully read the cautions on pages 107 and 108 before use.

SAFETY PRECAUTIONS

WARNING:
TO PREVENT FIRE OR SHOCK HAZARD, DO NOT EXPOSE THIS UNIT TO RAIN OR MOISTURE.

Warning on lithium cell battery (for remote control unit)

The battery used in this device may present a fire or chemical burn hazard if mistreated. Do not recharge, disassemble, heat above 100°C or incinerate.

Replace the battery with Maxell, Panasonic (Matsushita Electric), Sanyo or Sony CR2025; use of another battery may present a risk of fire or explosion.

- Dispose of used battery promptly.
- Keep away from children.
- Do not disassemble and do not dispose of in fire.

NOTES:

- *The rating plate (serial number plate) and safety caution are on the bottom and/or the back of the main unit.*
- *The rating plate (serial number plate) of the AC Power Adapter/Charger is on its bottom.*
- *The rating plate (serial number plate) of the Docking Station is on its bottom.*

CAUTIONS:

- If you notice smoke or a peculiar smell coming from the camcorder or AC adapter/charger, shut it down and unplug it immediately. Continue using the camcorder or AC adapter/charger under these conditions could lead to fire or electric shock. Contact your JVC dealer. Do not attempt to repair the malfunction yourself.
- To prevent shock, do not open the cabinet. No user serviceable parts inside. Refer servicing to qualified personnel.
- When you are not using the AC Power Adapter/Charger for a long period of time, it is recommended that you disconnect the power cord from AC outlet.

This camcorder is designed to be used with PAL-type colour television signals. It cannot be used for playback with a television of a different standard. However, live recording and LCD monitor/ viewfinder playback are possible anywhere. Use the BN-V507U/V514U battery packs and, to recharge them, the provided multi-voltage AC Power Adapter/Charger. (An appropriate conversion adapter may be necessary to accommodate different designs of AC outlets in different countries.)

This unit is produced to comply with Standard IEC Publ. 65.

SAFETY PRECAUTIONS

Do not point the lens or the viewfinder directly into the sun. This can cause eye injuries, as well as lead to the malfunctioning of internal circuitry. There is also a risk of fire or electric shock.

CAUTION!

The following notes concern possible physical damage to the camcorder and to the user.

When carrying, be sure to always attach and use the provided hand strap. Hold the camcorder firmly in your hand, with the strap securely around your wrist. Carrying or holding the camcorder by the viewfinder and/or the LCD monitor can result in dropping the unit, or in a malfunction.

Take care not to get your finger caught in the cassette cover. Do not let children operate the camcorder, as they are particularly susceptible to this type of injury.

Do not use a tripod on unsteady or unlevel surfaces. It could tip over, causing serious damage to the camcorder.

CAUTION!

Attaching the camcorder to the Docking Station with cables (Audio/Video, S-Video, Editing, DC, etc.) connected, then leaving it on top of the TV is not recommended, as tripping on the cables will cause the camcorder to fall, resulting in damage.

Mini **DV** PAL

MultiMediaCard

- This camcorder is designed exclusively for the digital video cassette and MultiMediaCard. Only cassettes marked "Mini **DV**" and memory cards marked "MultiMediaCard" can be used with this unit.

Before recording an important scene . . .

- make sure you only use cassettes with the Mini DV mark **Mini DV**.
- make sure you only use memory cards with the mark *MultiMediaCard*.
- remember that this camcorder is not compatible with other digital video formats.
- remember that this camcorder is intended for private consumer use only. Any commercial use without proper permission is prohibited. (Even if you record an event such as a show, performance or exhibition for personal enjoyment, it is strongly recommended that you obtain permission beforehand.)

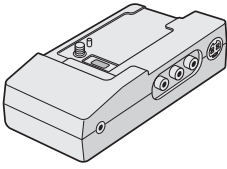

• Docking Station CU-V501E

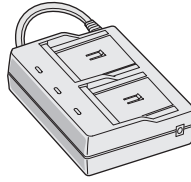

• AC Power Adapter/Charger
AA-V50A or AA-V50SH

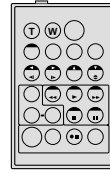

• Remote Control Unit
RM-V713U

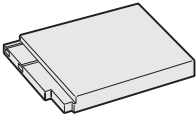

• Battery Pack BN-V507U

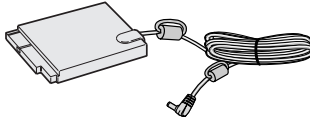

• DC Cord

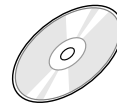

• CD-ROM
The CD ROM contains the following 7 software programmes:

- JLIP Video Capture
- JLIP Video Producer
- Picture Navigator (for Windows®)
- Picture Navigator (for Macintosh®)



• Lithium Battery CR2025
(for remote control unit)

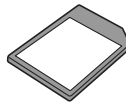

• MultiMediaCard

- Presto!
- Mr. Photo
 - PhotoAlbum
 - ImageFolio



• PC Connection Cable



• JLIP Cable

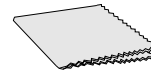

• Cleaning Cloth



• Audio/Video (A/V) Cable
[mini-plug to RCA plug]



• Audio/Video (A/V) Cable
[RCA plug to RCA plug]



• Core Filter x 3 (for optional
DV cable, headphones and
microphone)

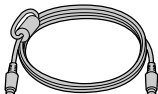

• S-Video Cable



• Editing Cable

The digital camcorder converts incoming audio and video signals into digital form for recording.

A video signal is composed of a luminance signal (Y) and colour signals (R-Y and B-Y). These signals are identified and recorded digitally (Digital Component Recording). The A/D (Analogue to Digital) converter samples the Y signal at 13.5 MHz, and R-Y and B-Y at 6.75 MHz, and changes them to an 8-bit quantum signal.

Sound sampled at 48 kHz is changed to a 16-bit quantum signal, and sound sampled at 32 kHz is converted to a 12-bit signal.

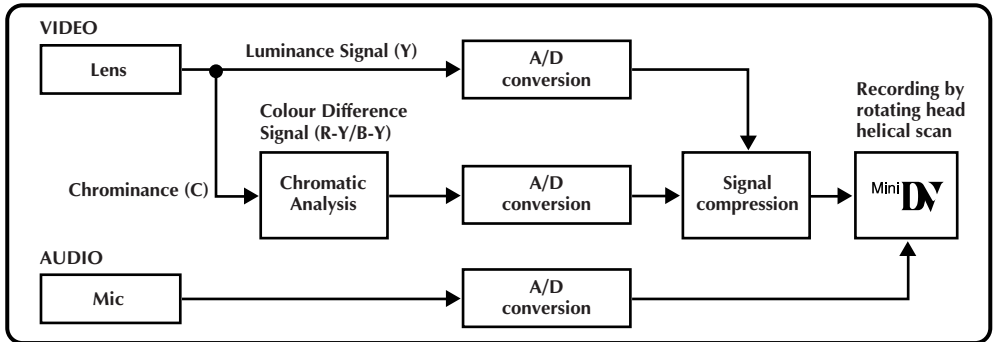

This camcorder separates the data into blocks, writing one block of each data type on each track of the tape.

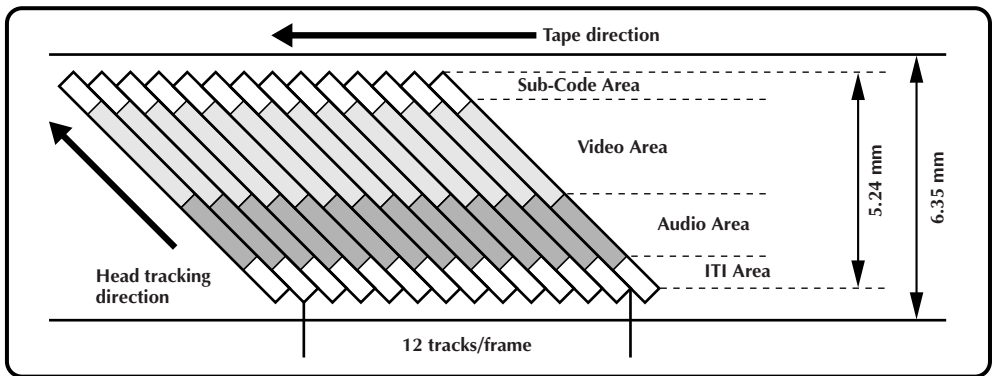

1 Sub-Code Area

The Time Code and Date/Time data are written here, separate from the video data. This enables you to display the date and time during playback, even if they weren't displayed while recording.

2 Video Area

The digital video signal is recorded here.

3 Audio Area

The digital audio signal is recorded here.

4 ITI (Insert and Tracking Information) Area

Insert editing and post-recording editing tracking signals are recorded here.

PROVIDED ACCESSORIES 4**ABOUT DV 5****GETTING STARTED 8 – 17**

Power	8
Grip Adjustment	10
Viewfinder Adjustment	10
Date/Time Settings	11
Loading/Unloading A Cassette	12
Recording Mode Setting	13
Loading A MultiMediaCard	14
Unloading A MultiMediaCard	14
Picture Quality Mode Setting	15
Tripod Mounting	16
Operation Mode	17

RECORDING 18 – 51

Basic Recording For Video	18
Basic Recording For Digital Still Camera (D.S.C.)	22
Basic Recording For Video And D.S.C.	24
Advanced Features For Video And D.S.C.	26

PLAYBACK 52 – 73

Basic Playback For Video	52
Advanced Features For Video	54
Basic Playback For D.S.C.	56
Advanced Features For D.S.C.	57
Advanced Features For Video And D.S.C.	68
Basic Connections	70
Advanced Connections	72

DUBBING 74 – 79

Dubbing Images/Sounds Recorded On A Tape To Another Tape	74
Digital Dubbing Of Recorded Images/Sounds Between Tapes	75
Dubbing Images Stored In A MultiMediaCard To A Tape	76
Dubbing Images Recorded On A Tape To A MultiMediaCard	77
Copying Images Using Infrared Communication [IrTran-P]	78

USING THE REMOTE CONTROL UNIT 80 – 90

Random Assemble Editing	84
For More Accurate Editing	88
Audio Dubbing	90

ADDITIONAL INFORMATION 91

Initializing A MultiMediaCard	91
-------------------------------------	----

TROUBLESHOOTING 92 – 97**USER MAINTENANCE** 98**INDEX** 99 – 106

Docking Station	99
Controls, Connectors And Indicators	100
Indications	102
Terms	106

CAUTIONS 107 – 108**SPECIFICATIONS** 109 – 110

Power

This camcorder's 2-way power supply system lets you choose the most appropriate source of power.

NOTES:

- No function is available without power supply.
- Use only specified power supply.
- Do not use provided power supply units with other equipment.

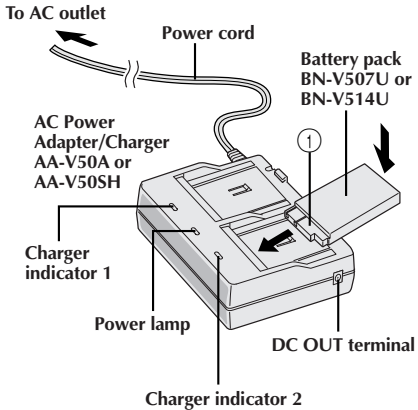

NOTES:

- Perform charging where the temperature is between 10° and 30°C. 20° to 25°C is the ideal temperature range for charging. If the environment is too cold, charging may be incomplete.
- Charging times noted above are for fully discharged battery pack.
- Charging time varies according to the ambient temperature and the status of the battery pack.
- To avoid interference with reception, do not use the AC Power Adapter/Charger near a radio.
- If you connect the camcorder's DC cord to the adapter during battery charging, power is supplied to the camcorder and charging stops.
- Since the AC Power Adapter/Charger processes electricity internally, it becomes warm during use. Be sure to use it only in well-ventilated areas.
- When charging the battery pack for the first time or after a long storage period, the charger indicator may not light. In this case, remove the battery pack from the AC Power Adapter/Charger, then try charging again.
- If the battery operation time remains extremely short even after having been fully charged, the battery is worn out and needs to be replaced. Please purchase a new one.

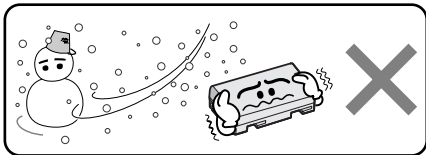

Lithium-ion is vulnerable in colder temperatures.

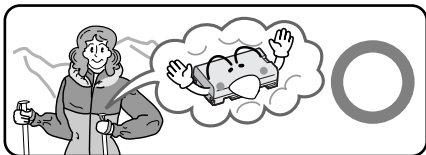

CHARGING THE BATTERY PACK

1 SUPPLY POWER TO CHARGER

Make sure you unplug the camcorder's DC cord from the AC Power Adapter/Charger.
Plug the AC Adapter/Charger's power cord into an AC outlet. The power lamp comes on.

2 ATTACH BATTERY/BATTERIES

Attach the battery pack while making sure its terminal side ① is in contact with the indicator side of the battery pack mount on the AC Power Adapter/Charger.

- The Charger Indicator (1 or 2) begins blinking to indicate charging has started.

3 CONFIRM STATUS

When the charger indicator stops blinking but stays lit, charging is finished.

- If two batteries are attached to the charger, they will be charged in the order that they were attached.

4 DETACH BATTERY/BATTERIES

Slide the battery or batteries in the opposite direction of the arrow and lift off. Remember to unplug the AC Adapter/Charger's power cord from an AC outlet.

Charging time

Battery pack	ONE	TWO
BN-V507U	approx. 1 hr. 30 min.	approx. 3 hrs.
BN-V514U (optional)	approx. 3 hrs.	approx. 6 hrs.

About Batteries

DANGER! Do not attempt to take the batteries apart, or expose them to flame or excessive heat, as it may cause a fire or explosion.

WARNING! Do not allow the battery or its terminals to come in contact with metals, as this can result in a short circuit and possibly start a fire.

The Benefits Of Lithium-Ion Batteries

Lithium-ion battery packs are small but have a large power capacity. However, when one is exposed to cold temperatures (below 10° C), its usage time becomes shorter and it may cease to function. If this happens, place the battery pack in your pocket or other warm, protected place for a short time, then re-attach it to the camcorder. As long as the battery pack itself is not cold, it should not affect performance.

(If you're using a heating pad, make sure the battery pack does not come in direct contact with it.)

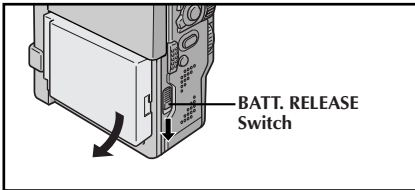
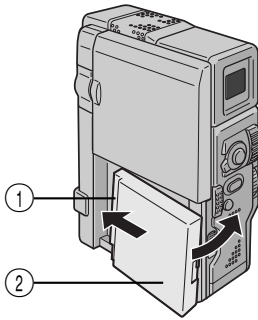

ATTENTION:

Before detaching the power source, make sure that the camcorder's power is turned off. Failure to do so can result in a camcorder malfunction.

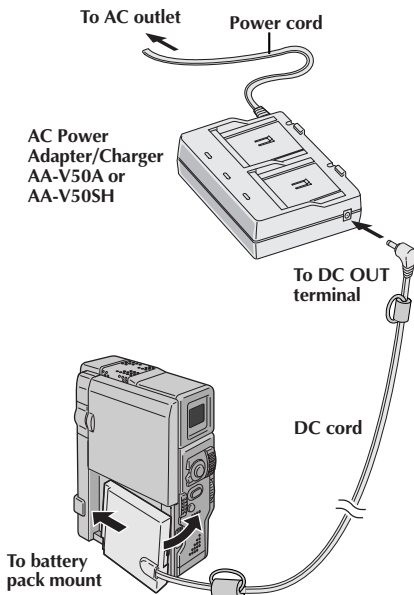

USING THE BATTERY PACK

1 ATTACH BATTERY PACK

Insert the terminal end ① of the battery pack into the battery pack mount, then firmly push the end ② of the battery pack in the direction of the arrow until it locks into place as shown in the illustration.

- If the battery pack is attached in the wrong position, a malfunction may occur.

To Detach The Battery Pack . . .

.... while sliding down **BATT. RELEASE**, detach it.

NOTES:

- Continuous shooting is possible when the temperature is approx. 20°C.
 - However, continuous shooting capability is reduced significantly under the following conditions:
 - The temperature is below 10°C.
 - Zoom or Record-Standby mode is engaged repeatedly.
 - The LCD monitor is used repeatedly.
- Before extended use, it is recommended that you prepare enough battery packs to cover 3 times the planned shooting time.

Approximate recording time

Battery pack	LCD monitor on/ Viewfinder off	LCD monitor off/ Viewfinder on
BN-V507U	55 min.	65 min.
BN-V514U	115 min.	130 min.
BN-V856U	7 hrs. 30 min.	8 hrs. 30 min.

INFORMATION:

VU-V856KIT is a set composed of the BN-V856U battery pack and AA-V80EG AC Power Adapter/Charger. Also read thoroughly the VU-V856KIT's instruction manuals.

It is impossible to charge the BN-V856U battery pack using the provided AC Power Adapter/Charger. Use the optional AA-V80EG AC Power Adapter/Charger.

USING AC POWER

Use the AC Power Adapter/Charger (connect as shown in the illustration).

NOTES:

- The provided AC Power Adapter/Charger features automatic voltage selection in the AC range from 110 V to 240 V.
- For other notes, see pg. 8.

START/STOP Button

Power Zoom Lever

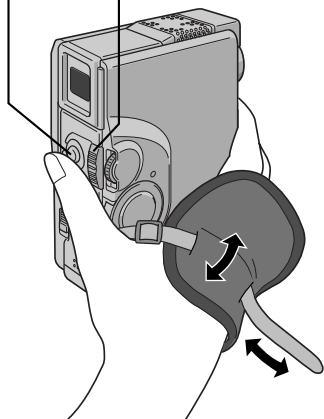

Grip Adjustment

- 1 EXPAND LOOP**
Separate the Velcro strip.
- 2 INSERT HAND**
Pass your right hand through the loop and grasp the grip.
- 3 ADJUST STRAP LENGTH**
Adjust so that your thumb and fingers can easily operate **START/STOP** and Power Zoom Lever.
Refasten the Velcro strip.

NOTE:

When carrying the camcorder inside a bag, etc., the grip belt's metal buckle may damage the camcorder. It is recommended that you place it inside the Velcro strip.

2

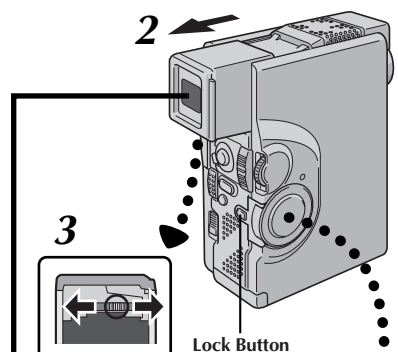

3

Lock Button

1

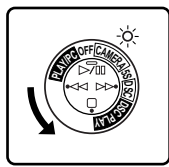

Set to "CAMERA" or "5S".

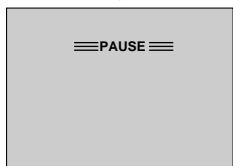

Viewfinder Adjustment

- 1 SELECT OPERATION MODE**
Set the Power Switch to "CAMERA" or "5S" while pressing down the Lock Button.
- 2 POSITION VIEWFINDER**
Pull out the viewfinder fully.
 - The power lamp comes on and the camcorder is turned on.
- 3 ADJUST DIOPTR**
Slide the Dioptre Adjustment Control until the indications in the viewfinder are clearly focused.

Operation Switch

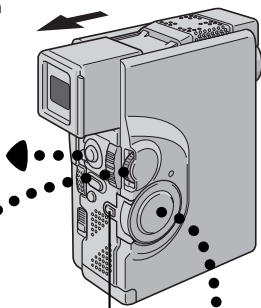
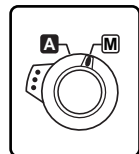

Lock Button

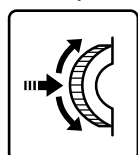

MENU/SET Dial

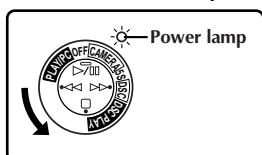

Power Switch

Display

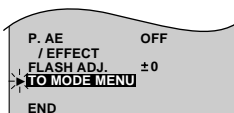

Recording Menu

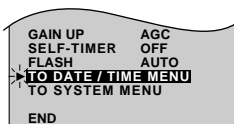

Mode Menu

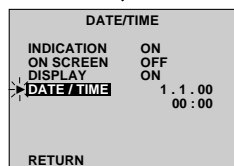

Date/Time Menu

Date/Time Settings

Date and time will automatically be recorded on tape at all times. It is your choice to display it or not during playback (▶ pg. 55).

1 **SELECT OPERATION MODE**

Set the Operation Switch to "M". Then, set the Power Switch to "CAMERA" or "5S" (or "DSC") while pressing down the Lock Button. Open the LCD monitor fully or pull out the viewfinder fully.

- The power lamp comes on and the camcorder is turned on.

2 **ACCESS RECORDING MENU**

Press MENU/SET. The Recording Menu appears.

3 **ACCESS MODE MENU**

Move the highlight bar to "TO MODE MENU" by rotating MENU/SET. Press it and the Mode Menu appears.

4 **ACCESS DATE/TIME MENU**

Move the highlight bar to "TO DATE/TIME MENU" by rotating MENU/SET. Press it and the Date/Time Menu appears.

5 **INPUT DATE AND TIME**

Move the highlight bar to "DATE/TIME" by rotating MENU/SET. Press it and "day" is highlighted and begins blinking. Rotating MENU/SET, input the day. Press it. Repeat the procedure to input the month, year, hour and minute.

- Press MENU/SET twice when the highlight bar is set to "RETURN" to exit.

Regarding Built-in Clock's Rechargeable Lithium Battery

To store the date/time in memory, the clock's rechargeable lithium battery is integrated in the camcorder. While the camcorder is connected to an AC outlet using the AC Power Adapter/Charger, or while the battery pack attached to the camcorder continues to supply power to the camcorder, the clock's rechargeable lithium battery is always charged. However, if the camcorder is not used for approx. 3 months, the clock lithium battery will become discharged and the date/time stored in memory will be lost. When this occurs, first connect the camcorder to an AC outlet using the AC Power Adapter/Charger for over 24 hours to charge the clock's rechargeable lithium battery. Then perform the date/time setting before using the camcorder. It is also possible to use the camcorder without the date/time setting.

NOTE:

Even if you select "DATE/TIME", if the parameter is not highlighted the camcorder's internal clock continues to operate. Once you move the highlight bar to the first date/time parameter (day), the clock stops. When you finish setting the minute and press MENU/SET, the date and time begin operation from the date and time you just set.

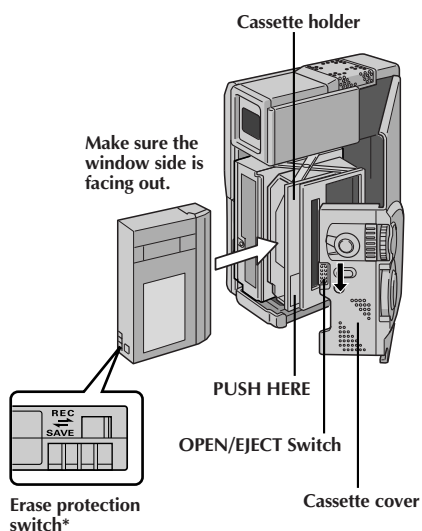

Loading/Unloading A Cassette

The camcorder needs to be powered up to load or eject a cassette.

1 OPEN CASSETTE COVER

Slide **OPEN/EJECT** in the direction of the arrow then swing the cover open until it locks. The holder opens automatically.

- Do not touch internal components.

2 INSERT/REMOVE TAPE

Insert or remove a tape and press "PUSH HERE" to close the cassette holder.

- Once the cassette holder is closed, it recedes automatically. Wait until it recedes completely before closing the cassette cover.
- When the battery's charge is low, you may not be able to close the cover. Do not apply force. Replace the battery with a fully charged one before continuing.

3 CLOSE CASSETTE COVER

Close the cassette cover firmly until it locks into place.

Approximate recording time

Tape	Recording mode	
	SP	LP
DVM-30	30 min.	45 min.
DVM-60	60 min.	90 min.

* To Protect Valuable Recordings . . .

.... slide the erase protection switch on the back of the tape in the direction of "SAVE". This prevents this tape from being recorded over. If you decide later that you do want to record on this tape, slide the switch back to "REC" before loading the tape.

NOTES:

- It takes a few seconds for the cassette holder to open. Do not apply force.
- If you wait a few seconds and the cassette holder does not open, close the cassette cover and try again. If the cassette holder still does not open, turn the camcorder off then on again.
- If the tape does not load properly, open the cassette cover fully and remove the cassette. A few minutes later, insert it again.
- When the camcorder is suddenly moved from a cold place to a warm environment, wait a short time before opening the cover.
- Closing the cassette cover before the cassette holder comes out may cause damage to the camcorder.
- Even when the camcorder is switched off, a cassette can be loaded or unloaded. After the cassette holder is closed with the camcorder switched off, however, it may not recede. It is recommended to turn the power on before loading or unloading.
- When resuming recording, once you open the cassette cover a blank portion will be recorded on the tape or a previously recorded scene will be erased (recorded over) regardless of whether the cassette holder came out or not. See page 25 for information about recording from the middle of a tape.

Operation Switch

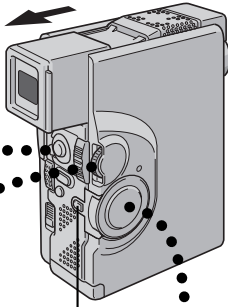
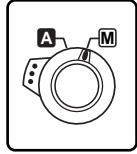

Lock Button

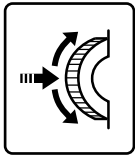

MENU/SET Dial

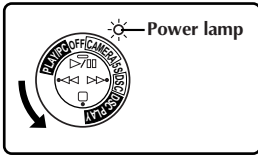

Power Switch

Display

FOCUS	AUTO
EXPOSURE	AUTO
W. BALANCE	AUTO
FADER	OFF
/ WIPE	
P. AE	OFF
/ EFFECT	
FLASH ADJ.	±0
TO MODE MENU	
END	

Recording Menu

REC MODE	SP
WIDE MODE	OFF
ZOOM	40X
DIS	ON \curvearrowright
GAIN UP	AGC
SELF-TIMER	OFF
FLASH	AUTO
TO DATE / TIME MENU	
TO SYSTEM MENU	
END	

Mode Menu

▶ REC MODE	SP
WIDE MODE	OFF
ZOOM	40X
DIS	ON \curvearrowright
GAIN UP	AGC
SELF-TIMER	OFF
FLASH	AUTO
TO DATE / TIME MENU	
TO SYSTEM MENU	
END	

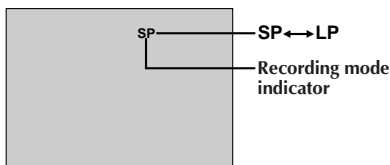

SP↔LP

Recording mode indicator

Recording Mode Setting

Set the tape recording mode according to your preference.

1 SELECT OPERATION MODE

Set the Operation Switch to "M". Then, set the Power Switch to "CAMERA" or "5S" while pressing down the Lock Button. Open the LCD monitor fully or pull out the viewfinder fully.

- The power lamp comes on and the camcorder is turned on.

2 ACCESS RECORDING MENU

Press MENU/SET. The Recording Menu appears.

3 ACCESS MODE MENU

Move the highlight bar to "TO MODE MENU" by rotating MENU/SET. Press it and the Mode Menu appears.

4 SET RECORDING MODE

First move the highlight bar to "REC MODE" by rotating MENU/SET. Press it and the parameter "SP" or "LP" is highlighted. Select "SP" or "LP" by rotating MENU/SET. Press it twice to exit from the Recording Menu.

- Audio Dubbing is impossible on a tape recorded in the LP mode.
- "LP" (Long Play) is more economical, providing 1.5 times the recording time.

NOTES:

- If the recording mode is switched during recording, the playback picture will be blurred at the switching point.
- It is recommended that tapes recorded in the LP mode on this camcorder be played back on this camcorder.
- During playback of a tape recorded on another camcorder, blocks of noise may appear or there may be momentary pauses in the sound.

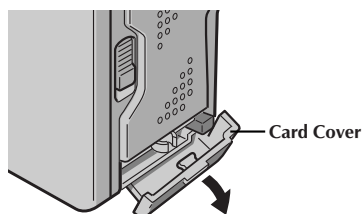

Card Cover

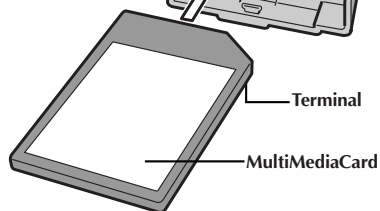
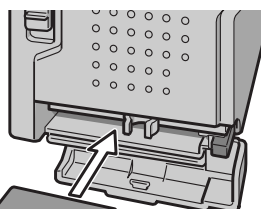

Terminal

MultiMediaCard

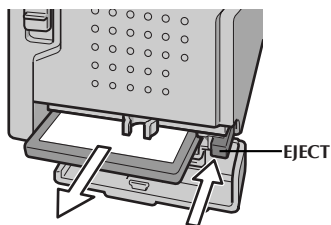
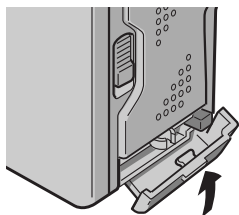

EJECT

Loading A MultiMediaCard

- 1 CONFIRM POWER-OFF STATUS**
Make sure the camcorder's power is off.
- 2 OPEN THE CARD COVER**
- 3 INSERT THE MULTIMEDIACARD**
Insert the MultiMediaCard terminal end first with the label facing up (see the illustration on the left).
 - Do not touch the terminal.
- 4 CLOSE THE CARD COVER**
 - If the card is not installed properly, the card cover cannot be closed.

NOTES:

- Be sure to use only MultiMediaCards marked "MultiMediaCard".
- Some brands of MultiMediaCards are not compatible with this camcorder. Before purchasing a MultiMediaCard, consult its manufacturer or dealer.

Unloading A MultiMediaCard

The MultiMediaCard retains images in its memory even after it has been removed from the camcorder.

- 1 CONFIRM POWER-OFF STATUS**
Make sure the camcorder's power is off.
- 2 OPEN THE CARD COVER**
- 3 REMOVE THE MULTIMEDIACARD**
Press **EJECT**. The MultiMediaCard is disengaged from the camcorder.
- 4 CLOSE THE CARD COVER**

ATTENTION:

Do not insert/remove the MultiMediaCard while the camcorder is turned on, as this may cause the MultiMediaCard to be corrupted or cause the camcorder to become unable to recognize whether or not the card is installed.

Operation Switch

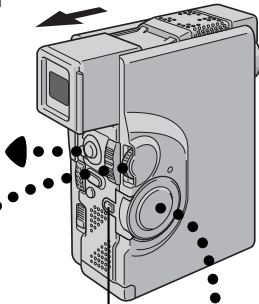
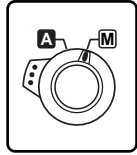

Lock Button

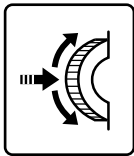

MENU/SET Dial

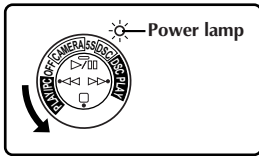

Power Switch

Display

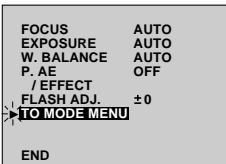

Recording Menu

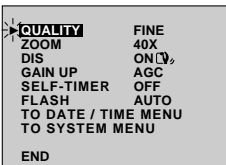

Mode Menu

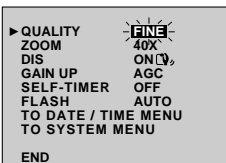

Picture Quality Mode Setting

The Picture Quality mode can be selected to best match your needs. Three Picture Quality modes are available: FINE, STANDARD and ECONOMY (in order of quality).

1 SELECT OPERATION MODE

Set the Operation Switch to "M". Then, set the Power Switch to "DSC" while pressing down the Lock Button.

Open the LCD monitor fully or pull out the viewfinder fully.

2 ACCESS RECORDING MENU

Press MENU/SET. The Recording Menu appears.

3 ACCESS MODE MENU

Move the highlight bar to "TO MODE MENU" by rotating MENU/SET. Press it and the Mode Menu appears.

4 SET PICTURE QUALITY MODE

First, move the highlight bar to "QUALITY" by rotating MENU/SET. Press it and the parameter "FINE", "STANDARD" or "ECONOMY" is highlighted. Select "FINE", "STANDARD" or "ECONOMY" by rotating MENU/SET. Press it twice to exit the Recording Menu.

NOTE:

The number of storable images depends on the selected Picture Quality mode as well as the size of the images.

Picture Quality Mode	Number of Storable Images (with provided MultiMediaCard)
FINE	Approximately 30
STANDARD	Approximately 50
ECONOMY	Approximately 100

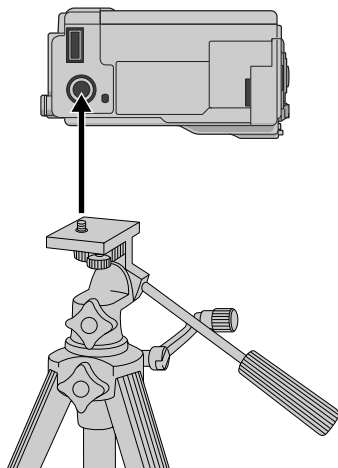

Tripod Mounting

1

ALIGN AND TIGHTEN

Align the screw on the tripod with the camera's mounting socket. Then tighten the screw.

CAUTION:

When using a tripod, be sure to open and extend its legs fully to stabilise the camcorder. To prevent damage to the unit caused by falling over, do not use a small-sized tripod.

To turn on the camcorder, first set the Power Switch to any operation mode except "OFF", then pull out the viewfinder fully or open the LCD monitor. When setting the Power Switch, press and hold the Lock Button.

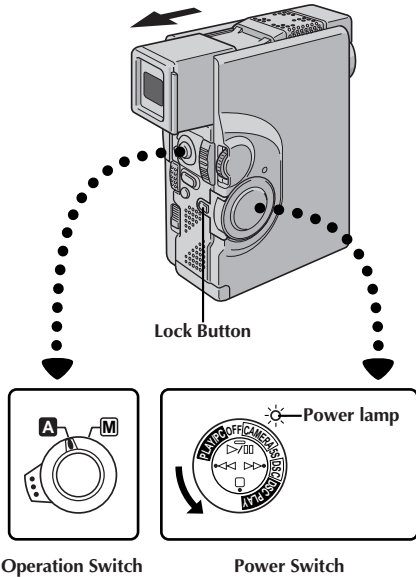

According to the Operation Switch position you have selected, "F.AUTO" or "MANUAL" appears in the upper left corner.

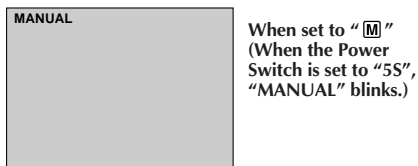
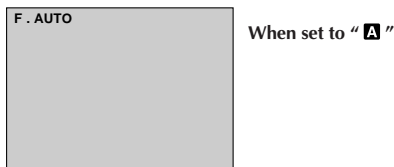

If the Power Switch is set to "PLAY/PC" or "DSC PLAY", these indications do not appear.

Operation Mode

Turning the Power Switch and Operation Switch allows you to choose the appropriate operation mode among the following table:

	Power Switch/ Operation Switch Position	Function
Power Switch Position	CAMERA	Suitable for standard recording on a tape.
	5 second recording mode: 5S	Allows you to record on a tape in 5-second clips to keep the action moving. Enables shooting in Manual mode. However, Focus and Exposure are the same as in the Full Auto mode, and it is not possible to change menu settings using the MENU/SET Dial.
	Digital Still Camera: DSC	Suitable for standard recording in the MultiMediaCard.
	PLAY/PC	Allows you to play back a recording on the tape or to transfer a still image recorded on the tape or in the MultiMediaCard to a computer.
	DSC PLAY	Allows you to display an image stored in the MultiMediaCard.
Operation Switch Position	OFF	Allows you to switch off the camcorder. After setting to this position, Manual Focus and Exposure Control are automatically reset to "AUTO".
	Full Auto: A	Allows you to record using NO special effects or manual adjustments. Suitable for standard recording.
	Manual: M	Allows you to set various recording functions using the Menus. If you want more creative capabilities than Full Auto recording, try this mode.

Operation Switch

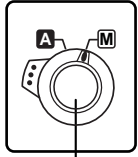
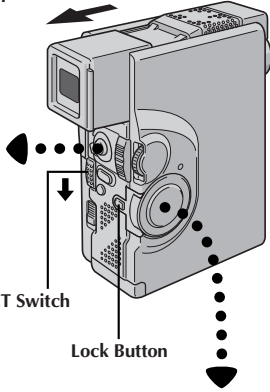
START/STOP
Button

OPEN/EJECT Switch

Lock Button

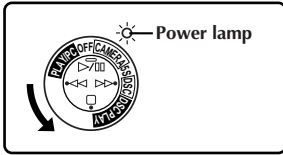

Power Switch

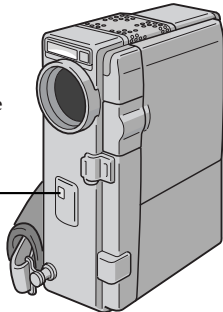
Tally lamp
(lights while
recording is
in progress)**NOTE:**

You should already have performed the procedures listed below. If not, do so before continuing.

- Power (☞ pg. 8)
- Grip Adjustment (☞ pg. 10)
- Viewfinder Adjustment (☞ pg. 10)
- Recording Mode Setting (☞ pg. 13)

1 LOAD A CASSETTE

Slide **OPEN/EJECT** in the direction of the arrow then swing the cover open until it locks. The holder opens automatically.

Insert a tape and press "PUSH HERE" to close the cassette holder.

- Once the cassette holder is closed, it recedes automatically. Wait until it recedes completely before closing the cassette cover.

Shooting While Watching The Viewfinder**2 ENTER RECORD-STANDBY MODE**

Make sure the LCD monitor is closed and locked. Set the Operation Switch to "**A**" or "**M**". Then, set the Power Switch to "**CAMERA**" while pressing down the Lock Button. Pull out the viewfinder fully.

- The lens cover opens, the power lamp lights and the camcorder enters the Record-Standby mode.
- The scene you are aimed at appears on the viewfinder screen, with the word "PAUSE" superimposed upon it.

3 START SHOOTING

Press **START/STOP**.

- "**REC**" appears in the viewfinder while recording is in progress.

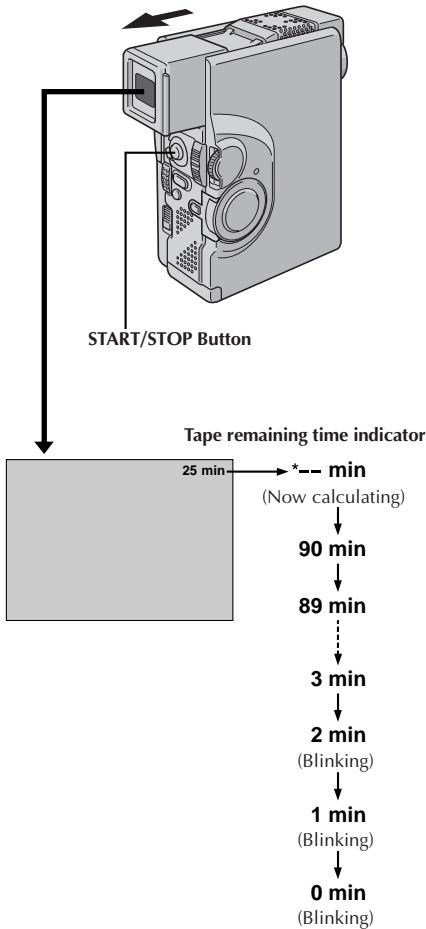

4 STOP RECORDING

Press **START/STOP** again to stop recording.

- The camcorder re-enters the Record-Standby mode.

NOTES:

- The image will not appear simultaneously in the LCD monitor and the viewfinder. No image appears on the LCD monitor when the viewfinder is pulled out. It is not possible to shoot using both LCD monitor and viewfinder. However, during Interface Shooting (☞ pg. 21) the image appears simultaneously in the LCD monitor and the viewfinder.
- The cassette holder cannot be opened unless a power supply is attached.
- There may be a delay after you open the cassette cover until the holder opens. Do not use force.
- The indicated tape remaining time is approximate.
- The time required to calculate and to display the remaining tape length, and the accuracy of the calculation, may vary according to the type of tape used.
- "TAPE END" appears when the tape reaches its end, and the power goes off automatically if left in this condition for 5 minutes. "TAPE END" also appears when a cassette whose tape is already at its end is loaded.
- If the Record-Standby mode continues for 5 minutes, the camcorder's power shuts off automatically. To turn the camcorder on again, push back and pull out the viewfinder again or close and re-open the LCD monitor.
- When a blank portion is left between recorded scenes on the tape, the time code is interrupted and errors may occur when editing the tape. Continue recording from where you stop so that there are no gaps by following "Recording from the middle of a tape" (☞ pg. 25).
- During recording, sound is not heard from the speaker. If you want to hear the sound, connect optional headphones to the headphones connector. The sound volume at this point is the same as the level it was adjusted during playback.
- To turn the tally lamp off during recording, refer to pgs. 34 – 39.

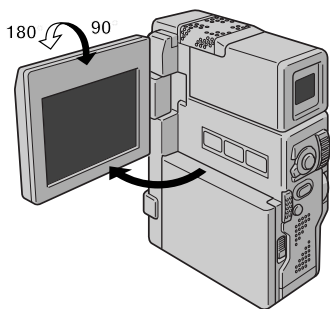

Operation Switch

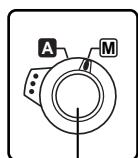

START/STOP Button

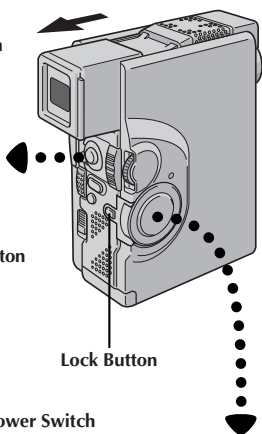

Lock Button

Power Switch

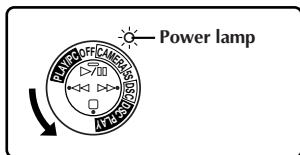

Power lamp

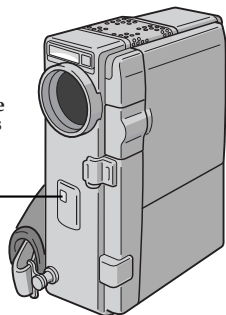
Tally lamp
(lights while
recording is
in progress)

Shooting While Watching The LCD Monitor

Before the following steps, perform step 1 (pg. 18).

2 ENTER RECORD-STANDBY MODE

Make sure the viewfinder is pushed back in. Set the Operation Switch to "A" or "M". Then, set the Power Switch to "CAMERA" while pressing down the Lock Button.

Open the LCD monitor fully.

- The lens cover opens, the power lamp lights and the camcorder enters the Record-Standby mode.
- The scene you are aimed at appears in the LCD monitor, with the word "PAUSE" superimposed upon it.

3 START SHOOTING

Tilt the LCD monitor upward/downward for best viewability (pg. 21) and press **START/STOP**.

- "REC" appears in the LCD monitor while recording is in progress.

4 STOP RECORDING

Press **START/STOP** again to stop recording.

- The camcorder re-enters the Record-Standby mode.

NOTES:

- When you use the LCD monitor outdoors in direct sunlight, the LCD monitor may be difficult to see. If this happens, we recommend that you use the viewfinder (pg. 18).
- To turn the tally lamp off during recording, refer to pgs. 34 – 39.
- For other notes, refer to pg. 19.

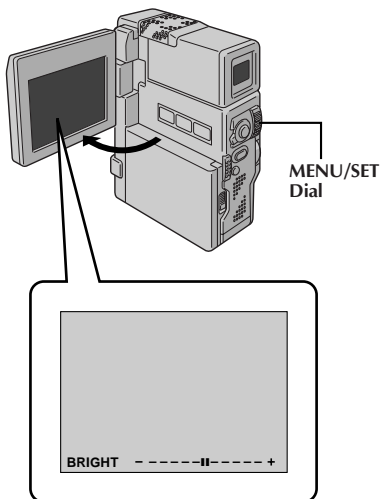

Journalistic Shooting

In some situations different angles of shooting may be required for more dramatic results.

1 OPEN LCD MONITOR

Make sure the LCD monitor is fully open.

2 TILT LCD MONITOR

Tilt the LCD monitor in the most convenient direction.

- The LCD monitor can rotate almost full circle (270°: 90° downward, 180° upward).

Interface Shooting

A person you shoot can view himself/herself in the LCD monitor, and you can even shoot yourself while viewing your own image in the LCD monitor.

1 TILT LCD MONITOR UPWARD

Open the LCD monitor and tilt it upward to 180 degrees so that it faces forward.

- The monitor image is inverted vertically. If the viewfinder is pulled out at that time, it will also switch on.

2 START RECORDING

Point the lens toward the subject (yourself when self-recording) and start recording.

- During Interface Shooting, the “Tape Running” indicator and warning indications (see pg. 102 – 105) are the only ones that are shown; they appear reversed in the display as they would when viewing a mirror, but are not reversed in the recording.

NOTE:

The tape remaining indicator does not appear during interface shooting. However, when the remaining time reaches 2 minutes, the indicator appears showing the remaining time: (blinking) (blinking) (blinking) (blinking)

Brightness Control

You can adjust the brightness of the display by rotating MENU/SET.

1 ADJUST BRIGHTNESS

Rotate MENU/SET until the brightness indicator moves and the display reaches its appropriate brightness.

- The brightness indication appears on the display.
- If the viewfinder is pulled out, it is also possible to adjust its brightness.

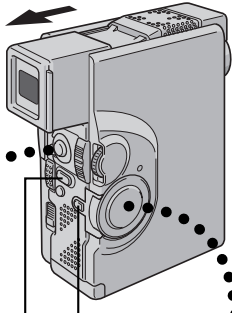

Lock Button
PHOTO (SNAPSHOT) Button

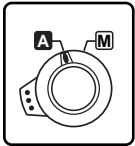

Operation Switch

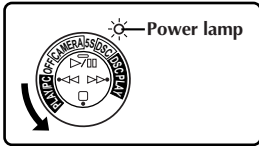

Power Switch

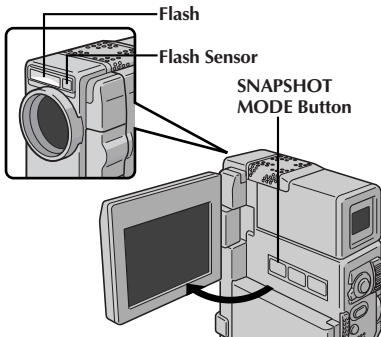

Basic Shooting (Snapshot)

You can use your camcorder as a Digital Still Camera (D.S.C.) for taking snapshots. Still images shot in the D.S.C. mode (when the Power Switch is set to "DSC") are recorded in the MultiMediaCard.

NOTE:

You should already have performed the procedures listed below. If you haven't, do so before continuing.

- Power (☞ pg. 8)
- Grip Adjustment (☞ pg. 10)
- Viewfinder Adjustment (☞ pg. 10)
- Loading A MultiMediaCard (☞ pg. 14)
- Picture Quality Mode Setting (☞ pg. 15)

SNAPSHOT MODE SELECTION

1 SELECT OPERATION MODE

Set the Operation Switch to "A" or "M". Then, set the Power Switch to "DSC" while pressing down the Lock Button. Open the LCD monitor fully or pull out the viewfinder fully.

2 SELECT SNAPSHOT MODE

Choose the appropriate mode from among the 5 snapshot modes available (☞ pg. 23) by pressing **SNAPSHOT MODE**.

Press **SNAPSHOT MODE** as many times as necessary until the desired snapshot mode indicator is displayed.

SNAPSHOT RECORDING

1 TAKE SNAPSHOT

Press **PHOTO (SNAPSHOT)**. The image is recorded in the MultiMediaCard.

- When the "⚡" flash ready indicator is displayed, the flash fires.

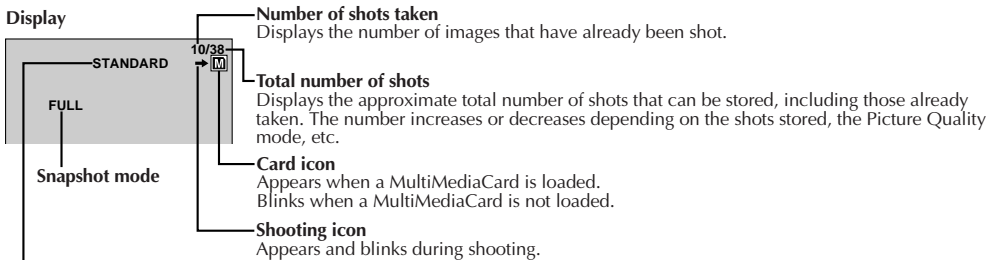

Picture Quality mode

Displays the Picture Quality mode of the stored image. There are 3 modes available: FINE, STANDARD and ECONOMY (in order of quality).



During snapshot



PIN-UP
Pin-Up mode*



FRAME
Snapshot mode
with frame*



FULL
Snapshot mode
with no frame*

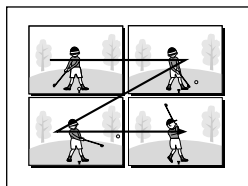

MULTI-4
Multi-Analyser 4

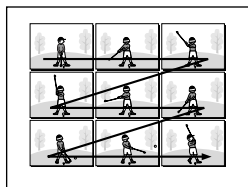

MULTI-9
Multi-Analyser 9

To Record An Image With A Title/Frame . . .

.... refer to "Superimposing A Title/Frame" (☞ pg. 69).

To Remove The Shutter Sound . . .

.... when you don't want to hear the shutter sound, set BEEP/TALLY to "OFF" in the System Menu (☞ pg. 34 – 39). The sound is no longer heard from the speaker.

NOTES:

- Even if "MULTI-4" or "MULTI-9" is engaged, Snapshot recording will be performed in the FULL mode during Digital Zoom. However, the flash will not fire.
- If Snapshot recording is not possible, "PHOTO" blinks when **PHOTO (SNAPSHOT)** is pressed.
- Even if Programme AE with special effects (☞ pg. 44, 45) is engaged, certain modes of Programme AE with special effects are disabled during Snapshot recording. In such a case, the icon blinks.
- If shooting is not performed for approx. 5 minutes when the Power Switch is set to "DSC" and power is supplied from the battery pack, the camcorder shuts off automatically to save power. To perform shooting again, close the LCD monitor and re-open it. When using the viewfinder, push back it in and pull it out again.
- Motor Drive Mode (☞ pg. 30) is disabled when the Power Switch is set to "DSC".
- To reduce the Red-Eye effect of the subject's eyes when the flash fires, ☞ pg. 32.
- When a cable or headphone set is connected to the AV OUT connector, the shutter sound is not heard from the speaker.

*: There is the sound of a shutter closing.

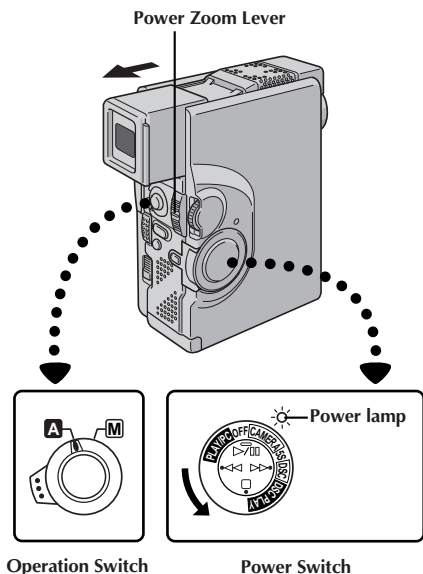
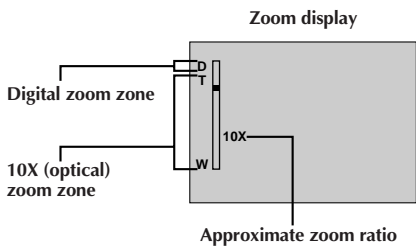
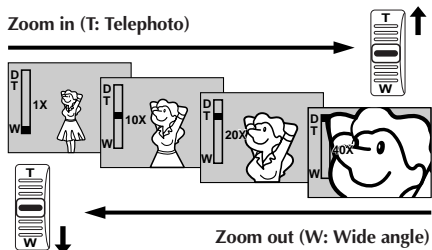

FEATURE: Zooming

PURPOSE:

To produce the zoom in/out effect, or an instantaneous change in image magnification.

OPERATION:

Zoom In

Slide the Power Zoom Lever towards "T".

Zoom Out

Slide the Power Zoom Lever towards "W".

- The further you slide the Power Zoom Lever, the quicker the zoom action.

NOTES:

- Focusing may become unstable during Zooming. In this case, set the zoom while in Record-Standby, lock the focus by using the manual focus (☞ pg. 47), then zoom in or out in Record mode.
- In Full Auto mode (when the Operation Switch is set to "A"), zoom magnification of up to 40X is possible. In Manual mode (when the Operation Switch is set to "M"), zooming is possible to a maximum of 200X or can be switched to 10X magnification offered by optical zoom.
- Zoom magnification of over 10X is done through Digital image processing, and is therefore called Digital Zoom.
- During Digital zoom, the quality of image may suffer.
- Digital zoom cannot be used while functions done through Digital image processing (Picture Wipe/Dissolve function, ☞ pg. 42, Video Echo, ☞ pg. 45, etc.) are activated.
- Macro shooting (as close as approx. 5 cm to the subject) is possible when the Power Zoom Lever is set all the way to "W". Also see "TELE MACRO" in the System Menu on page 39.

NOTE: Recording From The Middle Of A Tape

Time Code

During recording, a time code is recorded on the tape. This code is to confirm the location of the recorded scene on the tape during playback.

If recording starts from a blank portion, the time code begins counting from "00:00:00" (minute:second:frame). If recording starts from the end of a previously recorded scene, the time code continues from the last time code number.

To perform Random Assemble Editing (☞ pg. 84 – 89), time code is necessary. If during recording a blank portion is recorded partway through the tape, the time code is interrupted. When recording is resumed, the time code starts counting up again from "00:00:00". This means the camcorder may record the same time codes as those existing in a previously recorded scene. To prevent leaving a blank portion on a tape, perform the procedure in "Recording From The Middle Of A Tape" (see below) in the following cases;

- After playing back the recorded tape, when you shoot again.
- When power shuts off during shooting.
- When a tape is removed and re-inserted during shooting.
- When shooting using a partially recorded tape.
- When shooting on a blank portion located partway through the tape.
- When shooting again after already shooting a scene and opening/closing the cassette cover.

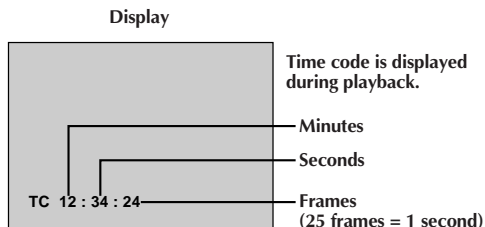

Recording From The Middle Of A Tape

1. Play back a tape to find the spot at which you want to start recording, then engage the Still Playback mode (☞ pg. 53).
2. Set the Operation Switch to "A" or "M". Then, set the Power Switch to "CAMERA" or "5S" while pressing down the Lock Button and start recording.

NOTES:

- The Time Code cannot be reset.
- During fast-forwarding and rewinding, time code indication does not move smoothly.

When blank portion is recorded on a tape

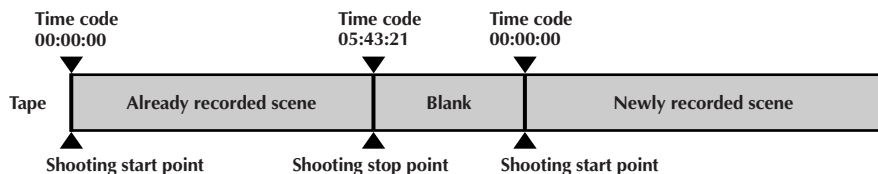

Proper recording

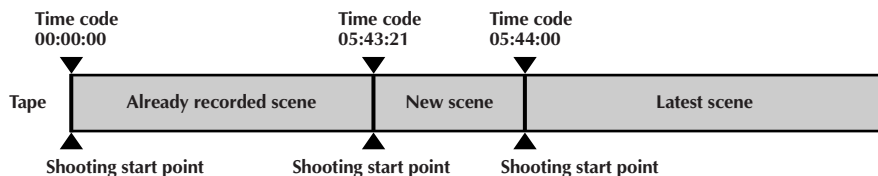

Operation Switch

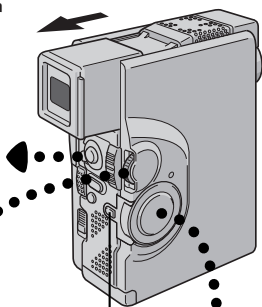
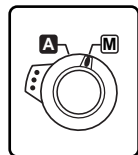

Lock Button

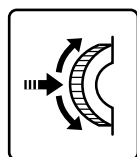

MENU/SET Dial

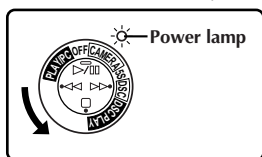

Power Switch

Display

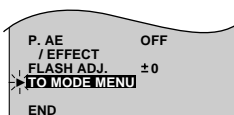

Recording Menu

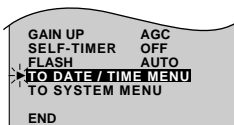

Mode Menu

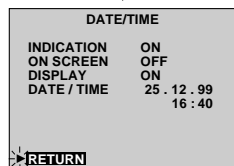

Date/Time Menu

Displaying The Date And Time During Recording

When the Operation Switch is set to "M", you can choose whether to display the date and time during recording or not. You must first set the date and time ("Date/Time Settings", pg. 11). Set "DISPLAY" to "ON" in the Date/Time Menu. The Date/Time is always displayed when the Operation Switch is set to "A".

1 SELECT OPERATION MODE

Set the Operation Switch to "M". Then, set the Power Switch to "CAMERA", "5S" or "DSC" while pressing down the Lock Button.

2 ACCESS RECORDING MENU

Press MENU/SET. The Recording Menu appears.

3 ACCESS MODE MENU

Move the highlight bar to "TO MODE MENU" by rotating MENU/SET. Press it and the Mode Menu appears.

4 ACCESS DATE/TIME MENU

Move the highlight bar to "TO DATE/TIME MENU" by rotating MENU/SET. Press it and the Date/Time Menu appears.

5 SELECT FUNCTION

Move the highlight bar to "DISPLAY" by rotating MENU/SET, then press it.

6 SET FUNCTION PARAMETERS

Cycle through the available settings of the selected functions by rotating MENU/SET and stop when the one you want is displayed. Then press it and the highlight bar automatically moves to "RETURN".

7 CLOSE RECORDING MENU

Press MENU/SET twice. Selection is complete and the menu disappears.

NOTES:

- Connect the camcorder to a TV and set "ON SCREEN" to "ON" in the Date/Time Menu. The display appears on the connected TV.
- Even if "ON SCREEN" is set to "ON", the indications are removed from the TV if "INDICATION" is set to "OFF" (pg. 27).

Operation Switch

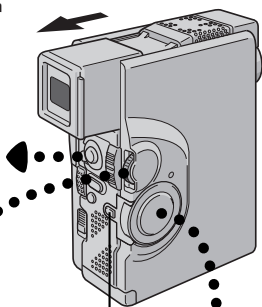
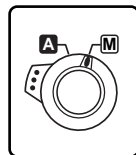

Lock Button

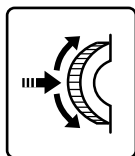

MENU/SET Dial

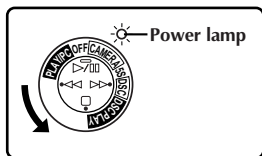

Power Switch

Display

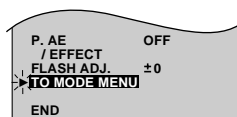

Recording Menu

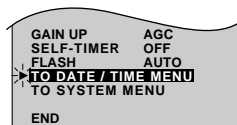

Mode Menu

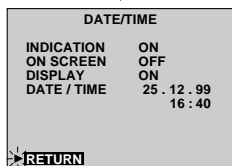

Date/Time Menu

LCD Monitor/Viewfinder Indications

You can make the LCD monitor/Viewfinder indications appear/disappear.

- 1 SELECT OPERATION MODE**
Set the Operation Switch to "M". Then, set the Power Switch to "CAMERA", "5S" or "DSC" while pressing down the Lock Button.
- 2 ACCESS RECORDING MENU**
Press MENU/SET. The Recording Menu appears.
- 3 ACCESS MODE MENU**
Move the highlight bar to "TO MODE MENU" by rotating MENU/SET. Press it and the Mode Menu appears.
- 4 ACCESS DATE/TIME MENU**
Move the highlight bar to "TO DATE/TIME MENU" by rotating MENU/SET. Press it and the Date/Time Menu appears.
- 5 SELECT FUNCTION**
Move the highlight bar to "INDICATION" by rotating MENU/SET, then press it.
- 6 SET FUNCTION PARAMETERS**
Cycle through the available settings of the selected functions by rotating MENU/SET and stop when the one you want is displayed.
OFF: To make the indications disappear.
ON: To make the indications appear.
Then press it and the highlight bar automatically moves to "RETURN".
- 7 CLOSE RECORDING MENU**
Press MENU/SET twice. Selection is complete and the menu disappears.

NOTES:

- It is impossible to make the tape running indicator "▶▶▶" and warnings etc. disappear from the LCD monitor or the viewfinder. For the indications that can be removed, see pg. 102, 103.
- If "INDICATION" is set in the Date/Time Menu, "INDICATION" in the Playback Menu will also be set to the same setting (see pg. 55).

Scene (5-second recording)

Record a vacation or an important event in 5-second clips to keep the action moving. This function is available only for video recording.

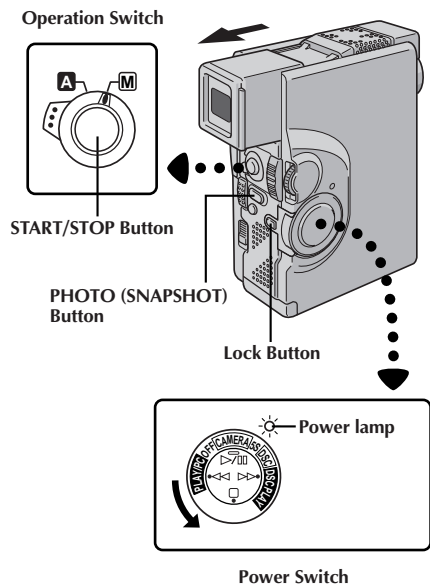

Display

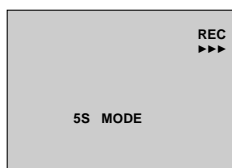

After 5 sec.

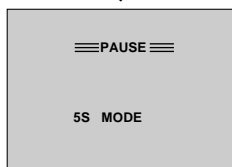

Record-Standby



Dissolves during 5 second recording mode

1 SELECT OPERATION MODE

Set the Operation Switch to "A" or "M", then set the Power Switch to "5S" while pressing down the Lock Button. Pull out the viewfinder fully or open the LCD monitor fully.

- "5S MODE" appears.

2 ENGAGE 5S MODE

Press **START/STOP**. The tally lamp lights and beep sounds to indicate the start of recording, and after 5 seconds the camcorder enters Record-Standby mode.

- If you press **START/STOP** again within 5 seconds after recording starts, Record-Standby mode is not engaged.
- If you press and hold **START/STOP**, recording continues until **START/STOP** is released.

3 END 5S MODE

Set the Power Switch to "CAMERA" or "OFF".

To Take A Snapshot In The 5-Second Recording Mode . . .

.... instead of pressing **START/STOP** in step 2, press **SNAPSHOT MODE** as many times as necessary until the desired snapshot indicator is displayed, then press **PHOTO (SNAPSHOT)**. The camcorder records a 5-second still (☞ pg. 30). When "SCENE" is set to "ANIM." (☞ pg. 34 – 39) this function is not available.

NOTES:

- When "SCENE" is set to "ANIM." in the System Menu, the 5-second recording mode is not available. Animation recording of a 1/3-second clip is taken instead (☞ pg. 34 – 39).
- While the 5-second recording mode is activated, Fade/Wipe effects (☞ pg. 43) and Programme AE with special effects (☞ pg. 45) cannot be performed. However, when "SCENE" is set to "5SD" in the System Menu (☞ pg. 39), the Dissolve function is available (see below).

Dissolves during 5 second recording mode

Set "SCENE" to "5SD" in the System Menu (☞ pg. 34 – 39). "5SD MODE" appears in step 1. Record one 5-second clip, and the image at the end of the clip is stored. If you record the next clip within 5 minutes, the previous scene dissolves as the new scene appears.

- If you turn the power off, the stored image will be lost.

Operation Switch

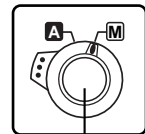
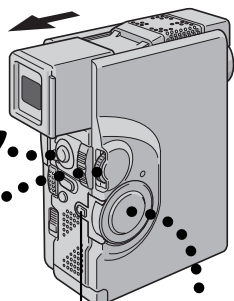
START/STOP
Button

Lock Button

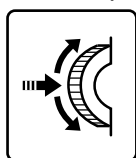

MENU/SET Dial

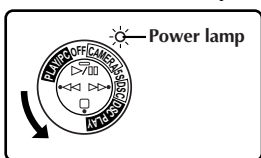

Power Switch

Display

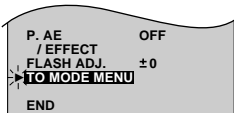

Recording Menu

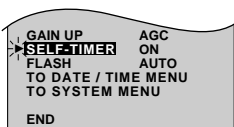

Mode Menu

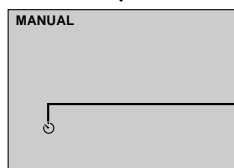
Self-Timer
indication

When START/STOP or
PHOTO (SNAPSHOT)
is pressed, the tally
lamp changes as shown:

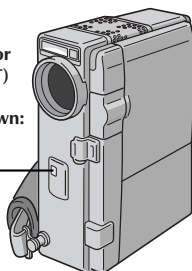

Self-Timer

Once the camcorder is set, the camcorder operator can become part of the scene in a more natural way, adding the final touch to a memorable picture.

1 SELECT OPERATION MODE

Set the Operation Switch to "M". Then, set the Power Switch to "CAMERA" or "DSC" (or "5S") while pressing down the Lock Button. Pull out the viewfinder fully or open the LCD monitor fully.

- You can tilt the LCD monitor upward to 180 degrees so that it faces forward and view yourself while self-recording with the viewfinder pushed back.

2 ACCESS RECORDING MENU

Press MENU/SET. The Recording Menu appears.

3 ACCESS MODE MENU

Move the highlight bar to "TO MODE MENU" by rotating MENU/SET. Press it. The Mode Menu appears.

4 SET SELF-TIMER

Move the highlight bar to "SELF-TIMER" by rotating MENU/SET. Press it and the parameter is highlighted. Rotate MENU/SET until "ON" appears. Press it twice to exit from the Recording Menu.

5 ENGAGE SELF-TIMER MODE

Press START/STOP. After 15 seconds, the beep sounds and video recording starts. To stop Self-Timer recording, press START/STOP again. The camcorder re-enters Record-Standby mode.

OR

Press PHOTO (SNAPSHOT). After 15 seconds, the beep sounds and snapshot recording starts. After that, the camcorder re-enters Record-Standby mode.

6 END SELF-TIMER RECORDING

Set the Operation Switch to "A" or set the Power Switch to "OFF". "SELF-TIMER" is automatically set back to "OFF".

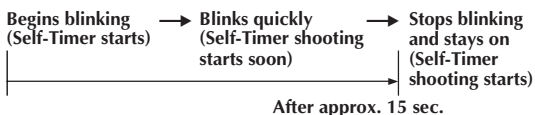

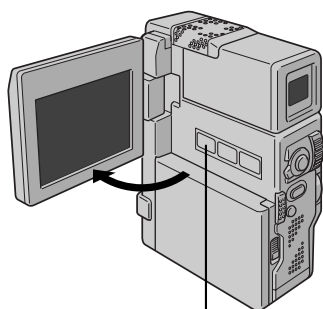
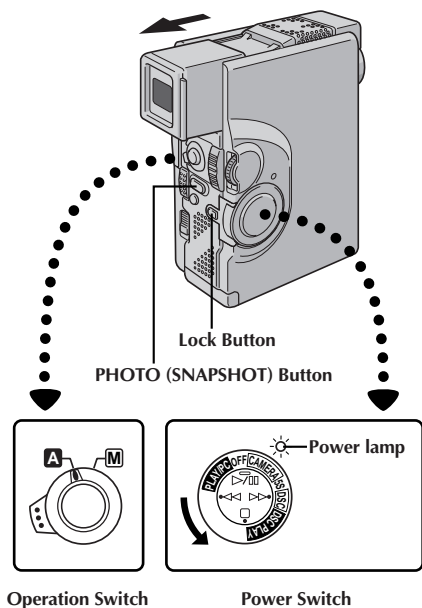

Display

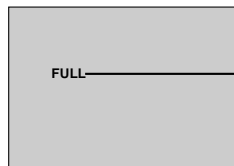

Snapshot mode

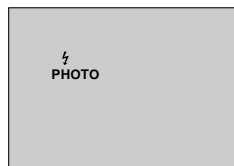

During snapshot

Snapshot (For Video Recording)

Use your camcorder like a regular camera and take a snapshot, or several of them in succession. This feature lets you record still images that look like photographs onto a tape.

SNAPSHOT MODE SELECTION

1 SELECT OPERATION MODE

Set the Operation Switch to "A" or "M". Then, set the Power Switch to "CAMERA" while pressing down the Lock Button. Pull out the viewfinder fully or open the LCD monitor fully.

2 SELECT SNAPSHOT MODE

Choose the appropriate mode from among the 5 Snapshot modes (☞ pg. 31) by pressing **SNAPSHOT MODE**.

Press **SNAPSHOT MODE** as many times as necessary until the desired snapshot mode indicator is displayed.

SNAPSHOT RECORDING

1 TAKE SNAPSHOT

Press **PHOTO (SNAPSHOT)**.

If you press during Record-Standby . . .

.... "PHOTO" appears and a still image will be recorded for approx. 6 seconds, then the camcorder re-enters the Record-Standby mode.

If you press during Recording . . .

.... "PHOTO" appears and a still image will be recorded for approx. 5 seconds, then the normal recording resumes.

- When the "⚡" flash ready indicator is displayed, the flash fires.

Motor Drive Mode

Keeping **PHOTO (SNAPSHOT)** pressed provides an effect similar to serial photography. (The interval between the still images: approx. 1 second.) However, when "REC SELECT" is set to "TAPE & CARD" in the System Menu (☞ pg. 39), the Motor Drive Mode does not take place.

To Remove The Shutter Sound . . .

.... when you don't want to hear the shutter sound, set BEEP/TALLY to "OFF" in the System Menu (☞ pg. 34 - 39). Though the sound is not heard from the speaker, it is recorded on the tape.



PIN-UP
Pin-Up mode*



FRAME
Snapshot mode
with frame*



FULL
Snapshot mode
with no frame*

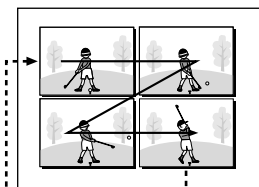

MULTI-4
Multi-Analyser 4

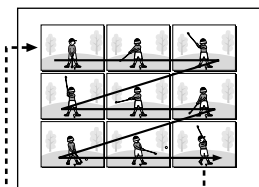

MULTI-9
Multi-Analyser 9

NOTES:

- Even if "MULTI-4" or "MULTI-9" is engaged, Snapshot recording will be performed in the FULL mode during Digital Zoom. However, the flash will not fire.
- If Snapshot recording is not possible, "PHOTO" blinks when **PHOTO (SNAPSHOT)** is pressed.
- Even if Programme AE with special effects (☞ pg. 44) is engaged, certain modes of Programme AE with special effects are disabled during Snapshot recording. In such a case, the icon blinks.
- When "REC SELECT" is set to "TAPE & CARD" in the System Menu (☞ pg. 39), still images are recorded not only onto the tape but also in the MultiMediaCard. If a tape is not loaded, they are recorded only in the MultiMediaCard, and if a MultiMediaCard is not loaded, the message "COPYING FAILED" appears and still images are recorded only onto the tape.
- If **PHOTO (SNAPSHOT)** is pressed during tape playback . . .
 - If a MultiMediaCard is not loaded: The message "COPYING FAILED" will appear, and a still image produced by the Snapshot mode will be displayed, in the same manner as during recording.
 - If a MultiMediaCard is loaded: A still image produced by the Snapshot mode will be recorded in the MultiMediaCard (☞ pg. 77).
- To reduce the Red-Eye effect of the subject's eyes when the flash fires, ☞ pg. 32.
- When a cable or headphone set is connected to the AV OUT connector, the shutter sound is not heard from the speaker, however it is recorded onto the tape.

*: There is the sound effect of a shutter closing.

Operation Switch

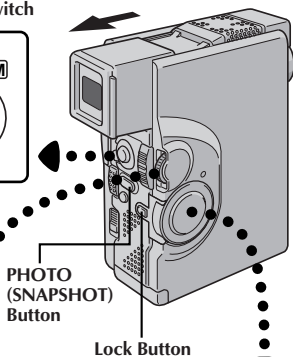
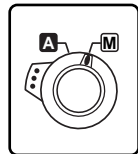
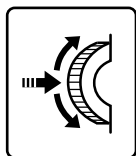
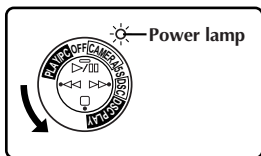

PHOTO (SNAPSHOT) Button

Lock Button



MENU/SET Dial



Power Switch

Display



Recording Menu

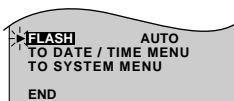

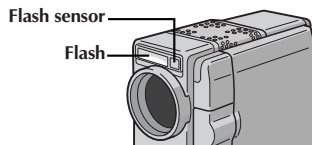

Mode Menu



Flash sensor

Flash

Snapshot Flash (Auto Flash)

In Full Auto or Manual mode, when "FLASH" is set to "AUTO" or "AUTO  " in the Mode Menu, the flash automatically fires if it's dark ( appears) when a snapshot is taken in Record-Standby.

By setting "FLASH" to "ON" or "OFF" in the Mode Menu, the flash can be activated or deactivated on demand.

To reduce the Red-Eye effect in the subject's eyes, it is recommended that you set "FLASH" to "AUTO  ". The flash automatically fires using this function when it is dark.

1 ENGAGE RECORD-STANDBY

Set the Operation Switch to "A" or "M". Then, set the Power Switch to "CAMERA", "5S" or "DSC" while pressing down the Lock Button. Pull out the viewfinder fully or open the LCD monitor fully.

If the Operation Switch is set to "A" ...
.... go to step 6.

If the Operation Switch is set to "M" ...
.... go to step 2.

2 ACCESS RECORDING MENU

Press MENU/SET. The Recording Menu appears.

3 ACCESS MODE MENU

Move the highlight bar to "TO MODE MENU" by rotating MENU/SET. Press it. The Mode Menu appears.

4 SELECT FUNCTION

Rotate MENU/SET to move the highlight bar to "FLASH", then press it.

5 SELECT FUNCTION PARAMETERS

Rotate MENU/SET to display the desired parameter ("AUTO", "ON", "OFF" or "AUTO  ") and press it. The parameter stops blinking and setting is complete. Press MENU/SET. The normal screen reappears.





6 TAKE SNAPSHOT

Press PHOTO (SNAPSHOT).

If "AUTO  " Is Selected In The Mode Menu ...

.... the  Red-Eye reduction indicator lights, then press PHOTO (SNAPSHOT). The flash fires twice. The first flash is for reduction of the human eye's red reflection and the second flash is for the actual recording.

NOTES:

- Do not fire the flash at a person at short range.
- In Multi-Analyzer 4 or Multi-Analyzer 9, the flash is disabled ( pg. 23, 31).
- The flash does not fire when the flash is set to "OFF" on the Mode Menu and also when the battery remaining power is low. Moreover, the flash does not fire when it is set to "AUTO" on the Mode Menu with GAIN UP set to "OFF" ( pg. 37) and with Programme AE with special effects set to "TWILIGHT" ( pg. 45).
- When taking several snapshots in succession (Motor Drive Mode), the flash fires only during the first one.
- Although images shot with a flash tend to look whiter than they actually are, to compensate for this the camcorder automatically darkens the picture when using the flash. When shooting a subject at a distance where the flash light cannot reach (over approx. 2 m), set the flash to "OFF" to prevent the picture from becoming too dark.
- The colour tone changes depending on the background lighting conditions, such as under fluorescent or halogen lamps.
- When you want to change the brightness of the flash, refer to "Flash Brightness Adjustment" ( pg. 33).
- While charging the flash,  blinks and the flash will not fire. Although noise may appear, this is not a malfunction and is not recorded. It can take up to ten seconds to charge the flash.

Operation Switch

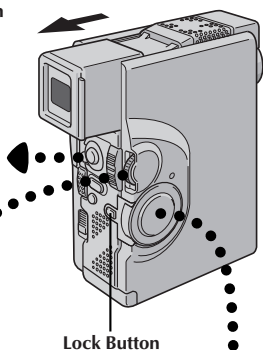
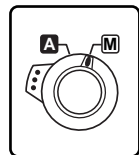

Lock Button

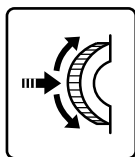

MENU/SET Dial

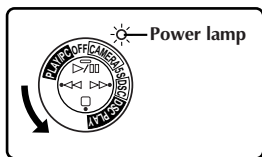

Power Switch

Display



Recording Menu

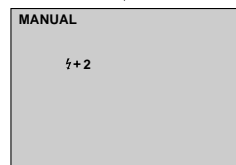
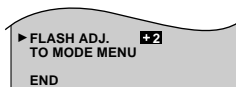

Flash Brightness Adjustment

When a snapshot (pg. 22, 30) is taken in the dark the camcorder fires the flash (pg. 32) and adjusts the brightness automatically. You can also adjust the flash brightness manually. When you find that the snapshots you took look too bright or too dark, adjust it manually.

1 SELECT OPERATION MODE

Set the Operation Switch to "M". Then, set the Power Switch to "CAMERA", "5S" or "DSC" while pressing down the Lock Button. Pull out the viewfinder fully or open the LCD monitor fully.

2 ACCESS RECORDING MENU

Press MENU/SET. The Recording Menu appears.

3 SELECT FUNCTION

Rotate MENU/SET to move the highlight bar to "FLASH ADJ.", then press it. The parameter blinks.

4 ADJUST BRIGHTNESS OF FLASH

Rotating MENU/SET upward increases the number of the brightness adjustment and rotating MENU/SET downward decreases it.

- The adjustment range is from -3 to +3.

5 ACTIVATE BRIGHTNESS OF FLASH

Press MENU/SET twice. The flash brightness adjustment is complete and the normal screen reappears.

NOTES:

- When the battery power is low or when "FLASH" is set to "OFF" in the Mode Menu, the "FLASH ADJ." setting cannot be changed.
- When you change the subject you are shooting or the shooting location, set it back to ± 0 as described in step 4 and take a snapshot to check the flash brightness. After doing this adjust to your desired brightness.

Operation Switch

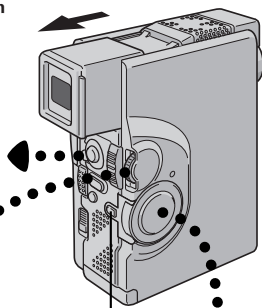
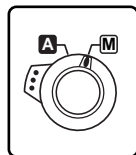

Lock Button

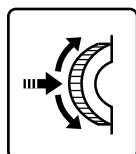

MENU/SET Dial

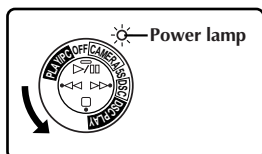

Power Switch

Using Menu For Detailed Adjustment

This camcorder is equipped with an easy-to-use, on-screen menu system that simplifies many of the more detailed camcorder settings (☞ pg. 35 – 39) .

1 SELECT OPERATION MODE

Set the Operation Switch to "M". Then, set the Power Switch to "CAMERA", "5S" or "DSC" while pressing down the Lock Button. Pull out the viewfinder fully or open the LCD monitor fully.

2 ACCESS RECORDING MENU

Press MENU/SET. The Recording Menu appears.

3 SELECT FUNCTION

Rotate MENU/SET to move the highlight bar to the desired function.

- If the setting you want cannot be found in the Menu Screen, place the highlight bar on "END", then go to step 7.

4 MAKE SETTING

Press MENU/SET. The setting procedure depends on the function you select.

If you select "FOCUS", "EXPOSURE", "W.BALANCE", "FADER/WIPE", "P.AE/EFFECT" or "FLASH ADJ." . . .

..... see respective pages (FOCUS: ☞ pg. 47, EXPOSURE: ☞ pg. 48, W.BALANCE: ☞ pg. 50, FADER/WIPE: ☞ pg. 41, P.AE/EFFECT: ☞ pg. 44, FLASH ADJ.,: ☞ pg. 33) and do each procedure from step 4.

If you select "TO MODE MENU" . . .

..... the Mode Menu appears. Go to step 5.

5 SELECT FUNCTION PARAMETERS IN MODE MENU

Rotate MENU/SET to move the highlight bar to the desired function and press it.

If you select a function other than "TO DATE/TIME MENU" or "TO SYSTEM MENU" . . .

..... each function's parameter starts blinking. Rotate MENU/SET until the desired parameter appears. Go to step 7.

If you select "TO DATE/TIME MENU" . . .

..... the Date/Time Menu appears. Go to step 6.

If you select "TO SYSTEM MENU" . . .

..... the System Menu appears. Go to step 6.

6 SELECT FUNCTION PARAMETERS IN DATE/TIME MENU OR SYSTEM MENU

Rotate MENU/SET to move the highlight bar to the desired function, then press it.

If you select "DATE/TIME" . . . ☞ pg. 11.

If you select other functions . . .

..... rotate MENU/SET until the desired parameter appears, then press it. The highlight bar automatically moves to "RETURN". Go to step 7.

7 CLOSE MENU SCREEN

Press MENU/SET as many times as necessary to return to the normal screen.

[Power Switch: **CAMERA** or 5S]

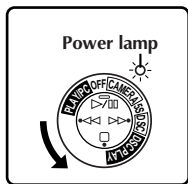

[Power Switch: **DSC**]

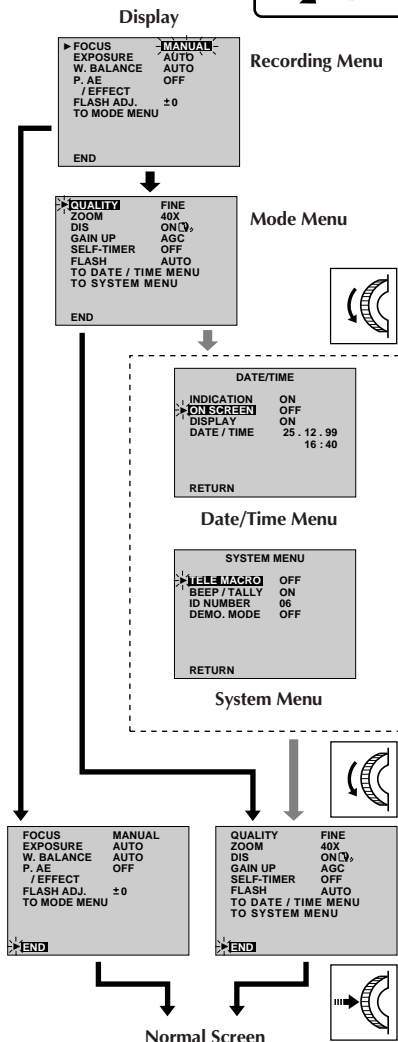
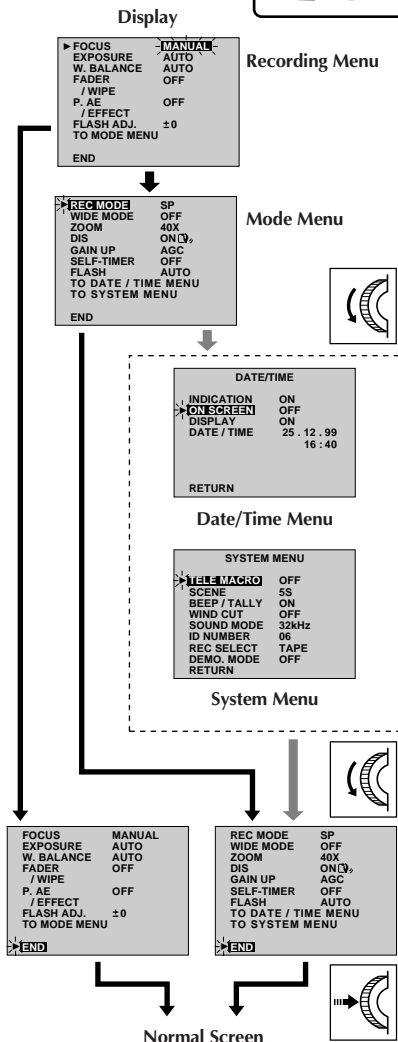
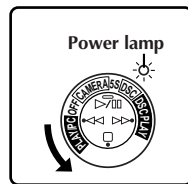





NOTES:

- "FADER/WIPE" appears in the Recording Menu only when the Power Switch is set to "CAMERA" or "5S".
- "REC MODE" and "WIDE MODE" appear in the Mode Menu only when the Power Switch is set to "CAMERA" or "5S".
- "QUALITY" appears in the Mode Menu only when the Power Switch is set to "DSC".
- "SCENE", "WIND CUT", "SOUND MODE" and "REC SELECT" appear in the System Menu only when the Power Switch is set to "CAMERA" or "5S".

Recording Menu Explanations

FOCUS	Refer to “Focusing” (☞ pg. 46, 47).
EXPOSURE	Refer to “Exposure Control” and “Iris Lock” (☞ pg. 48, 49).
W.BALANCE	Refer to “White Balance Adjustment” and “Manual White Balance Operation” (☞ pg. 50, 51).
FADER/WIPE	Refer to “Fade/Wipe Effects” (☞ pg. 41 – 43).
P.AE/EFFECT	Refer to “Program AE With Special Effects” (☞ pg. 44, 45).
FLASH ADJ.	Refer to “Flash Brightness Adjustment” (☞ pg. 33).
TO MODE MENU	Refer to “Mode Menu Explanations”. (☞ pg. 37).

Mode Menu Explanations





REC MODE	Allows you to set the recording mode (SP or LP) depending on your preference (☞ pg. 13).	
WIDE MODE	OFF	Select "OFF" when you want to use neither "SQUEEZE" nor "CINEMA".
	SQUEEZE ☑	For playback on TVs with an aspect ratio of 16:9. Naturally expands the image to fit the screen without distortion. ☑ appears. When using this mode, refer to your wide-screen TV's instruction manual. During playback/recording on 4:3 TVs/LCD monitor/viewfinder, the image is elongated vertically.
	CINEMA ☐	Inserts black bands at the top and bottom of the screen. During playback on wide-screen TVs, the black bands at the top and bottom of the screen are cut and the screen ratio becomes 16:9. When using this mode, refer to your wide-screen TV's instruction manual. During playback/recording on 4:3 TVs/LCD monitor/viewfinder, black bands are inserted at the top and bottom of the screen and the image appears like a letterboxed 16:9 movie.
QUALITY	Allows you to set the Picture Quality mode (FINE, STANDARD or ECONOMY) depending on your preference (☞ pg. 15).	
ZOOM	10X	When set to "10X" while using digital zoom, the zoom magnification will reset to 10X since digital zoom will be disengaged.
	40X	Allows you to use the Digital Zoom. By digitally processing and magnifying images, zooming is possible from 10 times (the optical zoom limit), to a maximum of 40 times digital magnification.
	200X	Allows you to use the Digital Zoom. By digitally processing and magnifying images, zooming is possible from 10 times (the optical zoom limit), to a maximum of 200 times digital magnification.
DIS	ON 	To compensate for unstable images caused by camera-shake, particularly at high magnification. NOTES: <ul style="list-style-type: none">• Accurate stabilisation may not be possible if hand shake is excessive, or under the following conditions:<ul style="list-style-type: none">• When shooting subjects with vertical or horizontal stripes.• When shooting dark or dim subjects.• When shooting subjects with excessive backlighting.• When shooting scenes with movement in various directions.• When shooting scenes with low-contrast backgrounds.• Switch off the Digital Image Stabilizer (DIS) when recording with the camcorder on a tripod.• The "" indicator appears blinking if the Stabilizer cannot be used.
	OFF	
GAIN UP	AGC	This is automatically activated during Full Auto mode. The overall appearance may be grainy, but the image is bright.
	AUTO 	The shutter speed is automatically adjusted (1/25 — 1/200 sec.). Shooting a subject in low or poor lighting at 1/25 sec. shutter speed provides a brighter image than in the AGC mode, but the subject's movements are not smooth or natural. When set to this mode, "  " is displayed.
	OFF	Allows you to shoot dark scenes with no picture brightness adjustment.
SELF-TIMER	Refer to "Self-Timer" (☞ pg. 29).	
FLASH	Refer to "Snapshot Flash (Auto Flash)" (☞ pg. 32).	
TO DATE/TIME MENU	Refer to "Date/Time Menu Explanations" (☞ pg. 38).	
TO SYSTEM MENU	Refer to "System Menu Explanations" (☞ pg. 39).	

Date/Time Menu Explanations

INDICATION	ON	Makes all the indications appear in the camcorder (☞ pg. 27).
	OFF	Keeps all the indications (except the tape running indicator, warnings, etc.) from appearing in the camcorder (☞ pg. 27).
ON SCREEN	OFF	Keeps the camcorder's display from appearing on the connected TV screen.
	ON	Makes the camcorder's display appear on screen when the camcorder is connected to a TV.
DISPLAY	ON	Makes the date/time settings appear in the camcorder (☞ pg. 26).
	OFF	Keeps the date/time settings from appearing in the camcorder.
DATE/TIME	Allows you to set the current date and time (☞ pg. 11).	

: Factory-preset

System Menu Explanations

TELE MACRO	OFF	Usually the distance to a subject where the lens is in focus depends on the zoom magnification. Unless there is a distance more than 1m to the subject, the lens is out of focus at the maximum telephoto setting. When set to "ON", you can shoot a subject as large as possible at a distance of approx. 60 cm. • Depending on the zoom position, the lens may go out of focus.
	ON	
SCENE	5S	 pg. 28.
	5SD	 pg. 28.
	ANIM.	Allows you to record a 1/3-second clip. By using an inanimate object and changing its position between shots, you can record the subject as though it is moving ( pg. 28).
BEEP/TALLY	ON	The tally lamp comes on to signal the start of recording. The beep sounds when the power is turned on or off, and at the beginning and end of recording. Also to activate the shutter sound effect ( pg. 23, 31).
	OFF	The tally lamp remains off at all times. Even though not heard while shooting, shutter sound is recorded on the tape.
WIND CUT	OFF	Disengages the function which cuts down on noise created by wind.
	ON	Helps cut down on noise created by wind. • "  " appears. • The quality of the sound will change. This is normal.
SOUND MODE	32 kHz	Enables recording of stereo sound on four separate channels, and is recommended for use when performing audio dubbing.
	48 kHz	Enables recording of stereo sound on two separate channels.
ID NUMBER	This number is necessary when connecting the camcorder to a device such as a computer using the J terminal (JLIP). The numbers range from 01 to 99. Factory setting is 06.	
REC SELECT	TAPE	When Snapshot recording is performed with the Power Switch set to " <u>CAMERA</u> " or "5S", still images are recorded only onto the tape.
	TAPE & CARD	When Snapshot recording is performed with the Power Switch set to " <u>CAMERA</u> " or "5S", still images are recorded not only onto the tape but also in the MultiMediaCard.
DEMO. MODE	OFF	Automatic demonstration will not take place.
	ON	Demonstrates certain functions such as Program AE with special effects, etc., and can be used to confirm how these functions operate. When "DEMO. MODE" is set to "ON" and the Recording Menu is closed, demonstration starts. NOTES: • If a tape is in the camcorder, the demonstration cannot be turned on. • By turning off the camcorder, "DEMO. MODE" is set to "OFF" automatically.

: Factory-preset

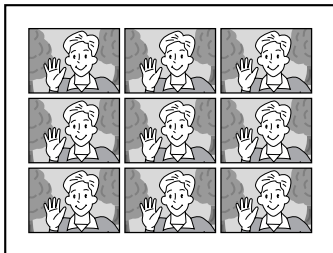
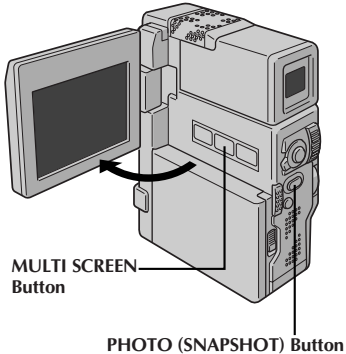
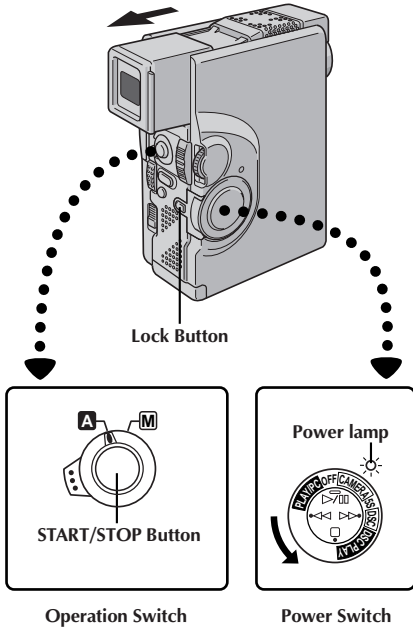

Multi Screen mode

Multi Screen Mode

The screen is divided into 9 quadrangles, with the scene you are aiming at appearing in each one. This 9-quadrangle image can be recorded onto a tape or into a MultiMediaCard.

1 SELECT OPERATION MODE

Set the Operation Switch to "A" or "M". Then, set the Power Switch to "CAMERA", "5S" or "DSC" while pressing down the Lock Button.

2 ACTIVATE MULTI SCREEN

Press MULTI SCREEN.

[Power Switch: "CAMERA"]

If you press MULTI SCREEN during recording . . .

.... the screen will be divided into 9 quadrangles and they will be recorded onto a tape.

[Power Switch: "CAMERA" or "5S"]

If you press MULTI SCREEN during Record-Standby . . .

.... the screen will be divided into 9 quadrangles. Press START/STOP to start recording with 9 quadrangles.

[Power Switch: "DSC"]

If you press MULTI SCREEN during Record-Standby . . .

.... the screen will be divided into 9 quadrangles. Press PHOTO (SNAPSHOT) to record with 9 quadrangles.

To Return To The Normal Screen . . .

.... press MULTI SCREEN again.

NOTES:

- In the Multi Screen mode, it is not possible to bring up the Menu Screen.
- During Digital Zoom, the Multi Screen mode is not available.
- The Multi Screen mode is available during video playback as well.

Operation Switch

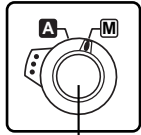
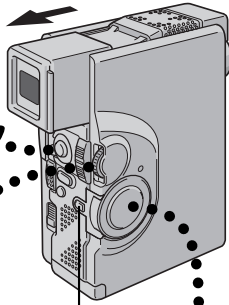
START/STOP
Button

Lock Button

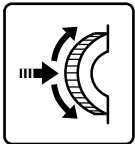

MENU/SET Dial

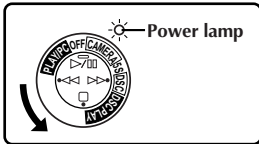

Power Switch

Display

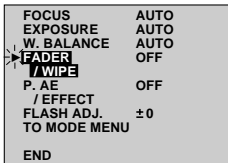

Recording Menu



FADER/WIPE Menu

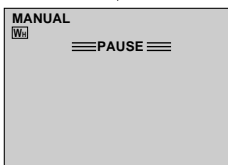
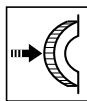
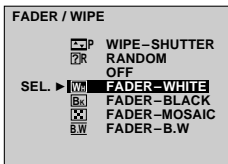

[Ex.: FADER - WHITE]

Fade-in



Fade-out

Fade/Wipe Effects

IMPORTANT:

If certain modes of Programme AE with special effects (pg. 44) are activated, some Fade/Wipe Effects cannot be used. If you select a Fade/Wipe Effect that is unusable in the current situation, the indication blinks.

These effects let you make pro-style scene transitions. Use these to spice up the transition from one scene to the next. You can also vary transitions from scene to scene. This function is available only when the Power Switch is set to "CAMERA".

EFFECT SELECTION

- 1 SELECT OPERATION MODE**
Set the Operation Switch to "M". Then set the Power Switch to "CAMERA" while pressing down the Lock Button. Pull out the viewfinder fully or open the LCD monitor fully.
- 2 ACCESS RECORDING MENU**
Press MENU/SET. The Recording Menu appears.
- 3 ACCESS "FADER/WIPE" MENU**
Rotate MENU/SET to move the highlight bar to "FADER/WIPE", then press it.
- 4 SELECT EFFECT**
Rotate MENU/SET to move the highlight bar to the desired function, then press it.
 - The FADER/WIPE Menu disappears and the effect is reserved. The indicator representing the selected effect appears.

FADE/WIPE SELECTION

(, , , , , , , and)

A scene gradually appears on a black, white, or black-and-white screen (Fade-in or Wipe-in); or disappears, leaving a black, white, or black-and-white screen (Fade-out or Wipe-out).

Fade or Wipe works when recording is started or when you stop recording.

Before the following step, perform the above steps 1 through 4.

- 5 START OR END RECORDING**
Press START/STOP to activate Fade-in/out or Wipe-in/out.

NOTE:

pg. 42.

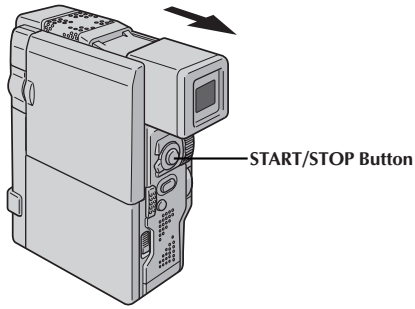

Previous scene end



[Ex.:  P WIPE – SCROLL]

Within 5 minutes . . .



Wipe-in

PICTURE WIPE OR DISSOLVE SELECTION

(, , , , ,  and )

Combine the Picture Wipe and Dissolve functions for a professional transition effect. There are 6 Picture Wipe effects and 1 Dissolve effect. The Picture Wipe or Dissolve works when recording is started.

Before the following steps, perform steps 1 through 4 on pg. 41.

5 STORE SCENE IN MEMORY

Engage the Record-Standby mode.

If you select Picture Wipe/Dissolve during recording . . .

.... press **START/STOP** when one scene is finished. The point at which the scene ended is stored in memory.

If you select Picture Wipe/Dissolve during Record-Standby mode . . .

.... press **START/STOP** to start recording and press it again when one scene is finished. The point at which the scene ended is stored in memory.

If you select Picture Wipe/Dissolve during Record-Standby mode after performing a Picture Wipe/Dissolve . . .

.... the point at which the scene ended is already stored in memory.



























6 START RECORDING

If you start recording a new scene within 5 minutes of the end of the previous recording (without having turned the camcorder's power off), the previous scene wipes out, revealing the new scene.

NOTES:

- You can extend the length of a Fade or Wipe by pressing and holding **START/STOP**.
- If the power is turned off after a scene is finished recording, the stored point is erased. This disables the Picture Wipe/Dissolve combination. When this happens, the Picture Wipe/Dissolve indicator blinks. Try recording again, but do not turn the power off when you are finished. Please be advised that power also shuts off automatically if 5 minutes elapse in the Record-Standby mode.
- The sound at the end of the last recorded scene is not stored.

Fader And Wipe Menu

Menu	Effect
 FADER — WHITE	Fade in or out with a white screen.
 FADER — BLACK	Fade in or out with a black screen.
 FADER — MOSAIC	Fade in or out with a full-screen mosaic effect.
 FADER — B.W	Fade in to a colour screen from a black and white screen, or fade out from colour to black and white.
 WIPE — CORNER	Wipe in on a black screen from the upper right to the lower left corner, or wipe out from lower left to upper right, leaving a black screen.
 WIPE — WINDOW	The scene starts in the centre of a black screen and wipes in toward the corners, or comes in from the corners, gradually wiping out to the centre.
 WIPE — SLIDE	Wipe in from right to left, or wipe out from left to right.
 WIPE — DOOR	Wipe in as the two halves of a black screen open to the left and right, revealing the scene, or wipe out and the black screen reappears from left and right to cover the scene.
 WIPE — SCROLL	The scene wipes in from the bottom to the top of a black screen, or wipes out from top to bottom, leaving a black screen.
 WIPE — SHUTTER	Wipe in toward the centre of a black screen from the top and bottom, or wipe out from the centre toward the top and bottom, leaving a black screen.
 P DISSOLVE	The new scene gradually appears as the old one gradually disappears.
 P WIPE — CORNER	The new scene wipes in over the previous one from the upper right corner to the lower left corner.
 P WIPE — WINDOW	The next scene gradually wipes in from the centre of the screen toward the corners, covering the previous scene.
 P WIPE — SLIDE	The next scene gradually wipes in over the previous one from right to left.
 P WIPE — DOOR	The previous scene wipes out from the centre to the right and left, like a door being pushed open to reveal the next scene.
 P WIPE — SCROLL	The new scene wipes in over the last one from the bottom of the screen to the top.
 P WIPE — SHUTTER	The new scene wipes in over the previous one from the centre toward the top and bottom of the screen.
 R RANDOM	When this function is activated, the camcorder randomly selects the effect used in scene transition (from  ,  ,  ,  ,  ,  ,  ,  , and ). The Picture Wipe/Dissolve function is not available.

Operation Switch

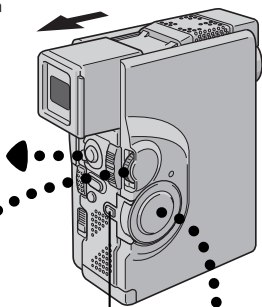
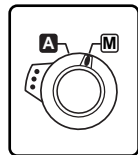

Lock Button

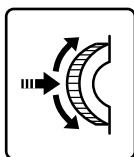

MENU/SET Dial

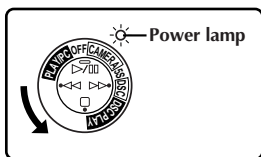

Power Switch

Display

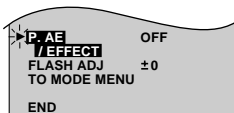

Recording Menu

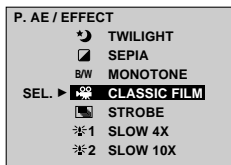

P.AE/EFFECT Menu



Programme AE With Special Effects

IMPORTANT:

If certain Fades or Wipes (see pg. 43) are activated, some modes of Programme AE with special effects cannot be used. If you select a mode that is unusable in the current situation, the mode's symbol blinks.

You can choose any one of the effects from the P.AE/EFFECT Menu.

1 SELECT OPERATION MODE

Set the Operation Switch to "M". Then set the Power Switch to "CAMERA" or "DSC" while pressing down the Lock Button. Pull out the viewfinder fully or open the LCD monitor fully.

2 ACCESS RECORDING MENU

Press MENU/SET. The Recording Menu appears.

3 ACCESS "P.AE/EFFECT" SELECT MENU

Rotate MENU/SET to move the highlight bar to "P.AE/EFFECT", then press it.

4 SELECT MODE

Move the highlight bar to the desired mode by rotating MENU/SET, then press it.

- The P.AE/EFFECT Menu disappears and the selected mode is activated. The symbol of the selected mode appears.

5 DISABLE MODE

To turn off the selected mode, re-access the P.AE/EFFECT Menu and move the highlight bar to "OFF" by rotating MENU/SET. Then press it.

NOTES:

- Programme AE with special effects can be changed during recording or during Record-Standby.
- The following modes are available only when the Power Switch is set to "CAMERA": "CLASSIC FILM", "STROBE" and "VIDEO ECHO".

The indicator for the selected mode appears, and the selected mode is engaged.



SHUTTER (Variable Shutter Speed)

1/50—The shutter speed is fixed at 1/50th of a second. Black bands that usually appear when shooting a TV screen become narrower.

1/100—The shutter speed is fixed at 1/100th of a second. The flickering that occurs when shooting under a fluorescent light or mercury-vapour lamp is reduced.

1/250, 1/500—These settings allow fast-moving images to be captured one frame at a time, for vivid, stable slow-motion playback. The faster the shutter speed, the darker the picture becomes. Use the shutter function under good lighting conditions.

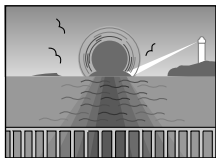

TWILIGHT

Makes evening scenes look more natural. White Balance (pg. 50) is initially set to , but can be changed to your desired setting. When Twilight is chosen, the camcorder automatically adjusts the focus from approx. 10 m to infinity. From less than 10 m, adjust the focus manually.



SEPIA

Recorded scenes have a brownish tint like old photos. Combine this with the Cinema mode for a classic look.

B/W MONOTONE

Like classic black and white films, your footage is shot in B/W. Used together with the Cinema mode, it enhances the “classic film” effect.



CLASSIC FILM*

Gives recorded scenes a strobe effect.



STROBE*

Your recording looks like a series of consecutive snapshots.

SLOW (Slow Shutter)

You can light dark subjects or areas even brighter than they would be under good natural lighting.



The Shutter Speed is set to 1/12.5th of a second to quadruple the sensitivity.



The Shutter Speed is set to 1/5th of a second to provide 10 times the sensitivity.

NOTES:

- When using “SLOW”, the image takes on a strobe-like effect.
- Use “SLOW” only in dark areas.
- The Manual Focus indication may appear and flash when “SLOW” is in use.
- If the image is out of focus, adjust manually. It is also recommended that you use a tripod, if possible.



VIDEO ECHO*

Adds a “ghost” to the subject, giving your recording a “fantasy” feeling.

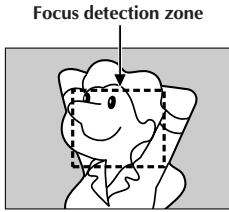

Focusing

AUTO FOCUS

The camcorder's Full Range AF system offers continuous shooting ability from close-up (as close as approx. 5 cm to the subject) to infinity. However, correct focus may not be obtainable in the situations listed below (in these cases use manual focusing):

- When two subjects overlap in the same scene.
- When illumination is low.*
- When the subject has no contrast (difference in brightness and darkness), such as a flat, one-colour wall, or a clear, blue sky.*
- When a dark object is barely visible in the viewfinder.*
- When the scene contains minute patterns or identical patterns that are regularly repeated.
- When the scene is affected by sunbeams or light reflecting off the surface of a body of water.
- When shooting a scene with a high-contrast background.

* The following low-contrast warnings appear blinking:

▲, ▲, ▼ and ☹

NOTES:

- If the lens is smeared or blurred, accurate focusing is not possible. Keep the lens clean, wiping with a piece of soft cloth if it gets dirty. When condensation occurs, wipe with a soft cloth or wait for it to dry naturally.
- When shooting a subject close to the lens, zoom-out first (☞ pg. 24). If zoomed-in in the auto focus mode, the camcorder could automatically zoom out depending on the distance between the camcorder and the subject. When "TELE MACRO" (☞ pg. 39) is activated, the camcorder will not zoom out automatically.

Operation Switch

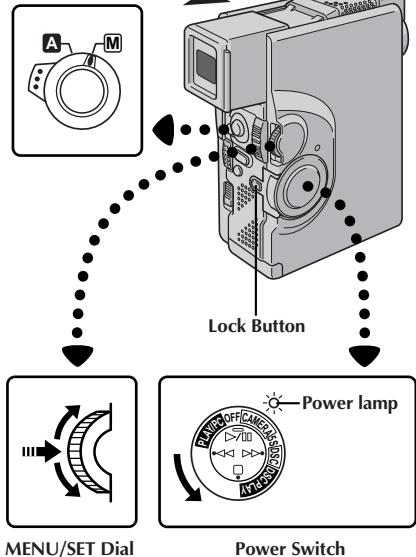

Display



Recording Menu

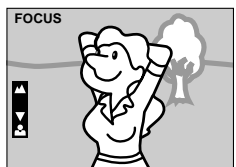
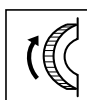
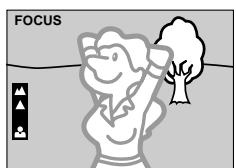

MANUAL FOCUS

NOTE:

You should already have made the necessary viewfinder adjustments (☞ pg. 10). If you have not, do so before continuing.

1 SELECT OPERATION MODE

Set the Operation Switch to "M". Then, set the Power Switch to "CAMERA", "5S" or "DSC" while pressing down the Lock Button. Pull out the viewfinder fully or open the LCD monitor fully.

2 ACCESS RECORDING MENU

Press MENU/SET. The Recording Menu appears.

3 ACCESS "FOCUS"

Rotate MENU/SET to move the highlight bar to "FOCUS", then press it.

4 ACCESS MANUAL FOCUS

Rotate MENU/SET to display "MANUAL", then press it. The Recording Menu disappears and "FOCUS" is displayed in the upper left corner. The focus is locked at this point.

5 ADJUST FOCUS

To farther subject . . .

.... rotate MENU/SET upward. "▲" appears and blinks. Go to step 6.

To nearer subject . . .

.... rotate MENU/SET downward. "▼" appears and blinks. Go to step 6.

6 END ADJUSTMENT OF FOCUS

Press MENU/SET. Focus adjustment is complete. The indication changes from "FOCUS" to "MANUAL".

• If you want to reset the focus, repeat from step 2.

To Change To Auto Focus . . .

.... rotate MENU/SET to display "AUTO" then press it in step 4. The manual focus indicators disappear. Or, set the Operation Switch to "A".

NOTES:

- After the Power Switch is set to "OFF", Manual Focus is reset to "AUTO".
- Be sure to focus the lens in the maximum telephoto position when you use the Manual Focus mode. If you focus in on a certain subject in the wide-angle position, sharply focused images cannot be obtained when zoomed up because the depth-of-field is reduced at longer focal lengths.
- When the focus level cannot be adjusted any farther or closer, "▲" or "▼" will blink.

Operation Switch

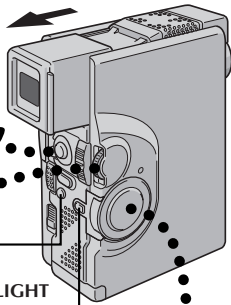
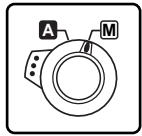
BACK LIGHT
Button

Lock Button

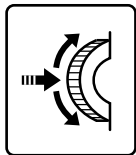

MENU/SET Dial

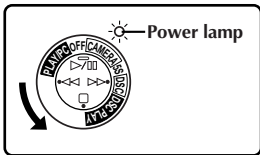

Power Switch

Display

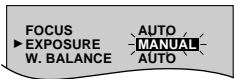

Recording Menu



To darken the image



Exposure control indicator

To brighten the image



Exposure Control

This feature automatically adjusts the iris for the best available picture quality, but you can override and make the adjustment manually.

1 SELECT OPERATION MODE

Set the Operation Switch to "M". Then, set the Power Switch to "CAMERA", "5S" or "DSC" while pressing down the Lock Button. Pull out the viewfinder fully or open the LCD monitor fully.

2 ACCESS RECORDING MENU

Press MENU/SET. The Recording Menu appears.

3 ACCESS "EXPOSURE"

Rotate MENU/SET to move the highlight bar to "EXPOSURE", then press it.

4 ACCESS EXPOSURE CONTROL

Rotate MENU/SET to display "MANUAL", then press it. The Recording Menu disappears. "EXP." and the highlight bar on the exposure control indicator are displayed.

5 ADJUST EXPOSURE

To brighten the image . . .

..... rotate MENU/SET upward. The exposure control indicator increases (maximum +6).
Go to step 6.

To darken the image . . .

..... rotate MENU/SET downward. The exposure control indicator decreases (maximum -6).
Go to step 6.

6 END ADJUSTMENT OF EXPOSURE

Press MENU/SET. Exposure adjustment is complete. The indication "EXP." changes to "MANUAL" and the highlight bar on the exposure control indicator goes out.

• If you want to reset the exposure, repeat step 2.



To Return To Automatic Exposure Control . . .

..... rotate MENU/SET to display "AUTO" then press it in step 4. The exposure control indicator disappears. Or set the Operation Switch to "A".

NOTES:

- After the Power Switch is set to "OFF", Exposure Control is reset to "AUTO".
- Manual exposure adjustment is recommended in the following situations:
 - When shooting using reverse lighting or when the background is too bright.
 - When shooting on a reflective natural background such as at the beach or when skiing.
 - When the background is overly dark or the subject light.

To Brighten The Subject Quickly . . .

..... press BACK LIGHT.  is displayed and the subject is brightened. If pressed again,  disappears and the brightness returns to the previous level. The value shown by the exposure control indicator plus 2 is the back light compensation level. The maximum compensation level is +6. Back light compensation is also available when the Operation Switch is set to "A".

Operation Switch

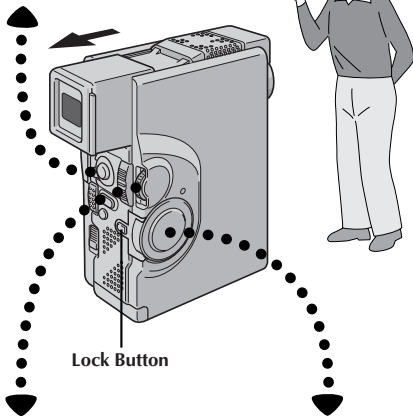
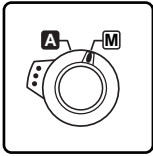

Lock Button

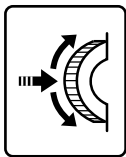

MENU/SET Dial

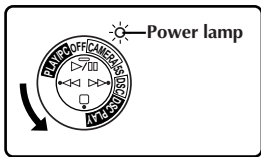

Power Switch

Display

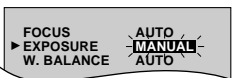

Recording Menu



Iris lock indicator

Iris Lock

Use this function when shooting a moving subject, when zooming, when the subject changes its distance (thus its size in the LCD monitor or the viewfinder), or when you want to lock the brightness level.

When the subject is close, keep the iris locked. Even when the subject moves away from you, the image will not darken or brighten.

1 SELECT OPERATION MODE

Set the Operation Switch to "M". Then, set the Power Switch to "CAMERA", "5S" or "DSC" while pressing down the Lock Button. Pull out the viewfinder fully or open the LCD monitor fully.

2 ACCESS RECORDING MENU

Press MENU/SET. The Recording Menu appears.

3 ACCESS "EXPOSURE"

Rotate MENU/SET to move the highlight bar to "EXPOSURE", then press it.

4 ACCESS EXPOSURE CONTROL

Rotate MENU/SET to display "MANUAL", then press it. "EXP." is displayed.

5 CENTRE SUBJECT, LOCK IRIS

Adjust zoom so that the subject fills the LCD monitor or the viewfinder, then press and hold MENU/SET for over 2 seconds. The exposure control indicator and "L" appear, indicating that the iris is locked. Press MENU/SET. The indication displayed in the upper left corner changes from "EXP." to "MANUAL".

To Return To Automatic Iris Control . . .

.... rotate MENU/SET to display "AUTO" then press it in step 4. The exposure control indicator and "L" disappear. Or, set the Operation Switch to "A".

NOTE:

Iris lock is recommended in the following situations:

- When shooting on a reflective natural background such as at the beach or when skiing.
- When shooting objects under a spotlight.
- When the subject is backing away.
- When zooming.

To Lock The Exposure Control And The Iris . . .

.... after step 4, adjust the exposure rotating MENU/SET. Then lock the iris in step 5. For automatic locking, rotate MENU/SET to display "AUTO", then press it in step 4. The iris becomes automatic after about 2 seconds.

Iris

Works like the pupil of the human eye. In a well-lit environment, the human pupil contracts to keep too much light from entering. In low lighting, the pupil dilates to allow more light in.

Operation Switch

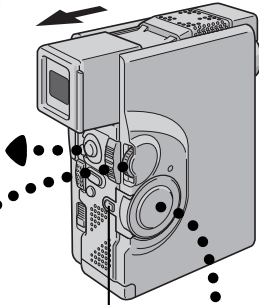
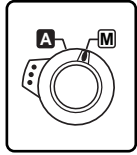

Lock Button

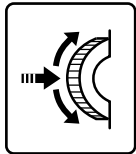

MENU/SET Dial

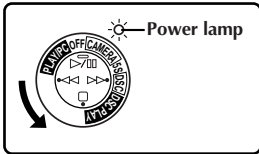

Power Switch

Display

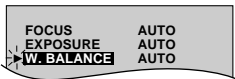

Recording Menu

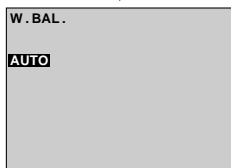

White Balance Adjustment

White Balance Adjustment

A term that refers to the correctness of colour reproduction under various lighting. If the white balance is correct, all other colours will be accurately reproduced.

The white balance is usually adjusted automatically. However, the more advanced camcorder operator would prefer to control this function manually and achieve a more professional colour/tint reproduction.

1 SELECT OPERATION MODE

Set the Operation Switch to "M". Then, set the Power Switch to "CAMERA", "5S" or "DSC" while pressing down the Lock Button. Pull out the viewfinder fully or open the LCD monitor fully.

2 ACCESS RECORDING MENU

Press MENU/SET. The Recording Menu appears.

3 ACCESS "W.BALANCE"

Rotate MENU/SET to move the highlight bar to "W.BALANCE", then press it.

4 ACCESS WHITE BALANCE ADJUSTMENT

The Recording Menu disappears. "W.BAL." appears in the upper left corner and the currently selected mode indication is also displayed.

5 SET FUNCTION PARAMETERS

Cycle through the available settings of the selected functions by rotating MENU/SET, and stop when the one you want is displayed.

"AUTO" – The white balance is adjusted automatically. This is the factory preset position.

"☑" – When shooting with the white balance already having been set on the subject (☞ pg. 51).

"☀" – When shooting outdoors on a sunny day.

"☁" – When shooting outdoors on a cloudy day.

"☛" – When using a video light or other similar type of lighting.

6 CLOSE WHITE BALANCE ADJUSTMENT

Press MENU/SET again. Selection is complete. The indication "W.BAL." changes to "MANUAL".

To Return To Automatic White Balance . . .

.... select "AUTO" in step 5. Or, set the Operation Switch to "A".

NOTE:

White balance cannot be used when Sepia or Monotone (☞ pg. 45) is activated.

Manual White Balance Operation

If the camera is operating in Manual mode “M”, perform Manual White Balance when shooting under various types of lighting.

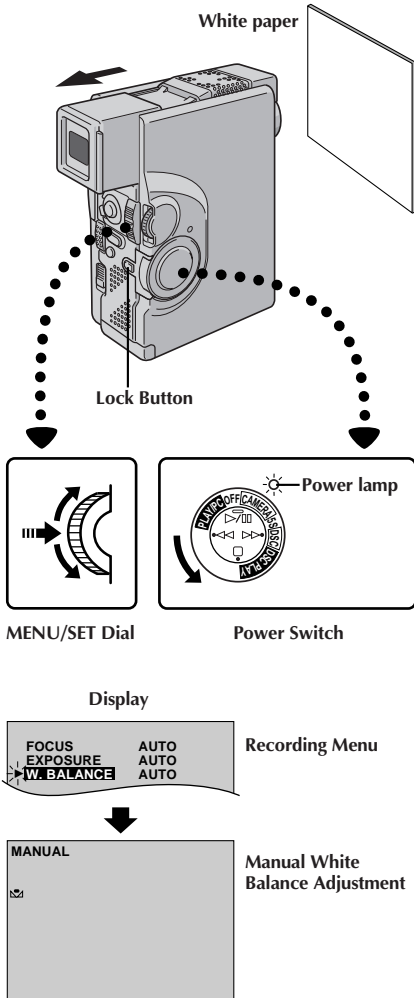

1 SELECT OPERATION MODE

Follow steps 1 through 5 of the white balance adjustment (☞ pg. 50), and select “MAN.”.

2 SET MANUAL WHITE BALANCE

Hold a sheet of plain white paper in front of the subject. Adjust zoom or position yourself so that the white paper fills the screen.

3 ENTER SETTING

Press MENU/SET until ☑ begins blinking.

• When the setting is completed, ☑ stops blinking.

4 EXIT MANUAL WHITE BALANCE ADJUSTMENT

Press MENU/SET. The indication “W.BAL.” changes to “MANUAL” and only the Manual White Balance indicator ☑ is displayed.

To Change The Tint For Recording . . .

.... in step 2, substitute coloured paper for white. The white balance is adjusted based on the colour, changing the tint. Red paper — deeper green; blue paper — orange; yellow paper — deeper purple.

NOTES:

- In step 2, it may be difficult to focus on the white paper in some circumstances. In such a case, adjust focus manually (☞ pg. 47).
- A subject can be shot under various types of lighting conditions indoors (natural, fluorescent, candlelight, etc.). Because the colour temperature is different depending on the light source, the tint of the subject will differ depending on the white balance settings. Use this function for a more natural result.
- Once you adjust white balance during Manual White Balance operation, the setting is retained even if the power is turned off or the battery removed.

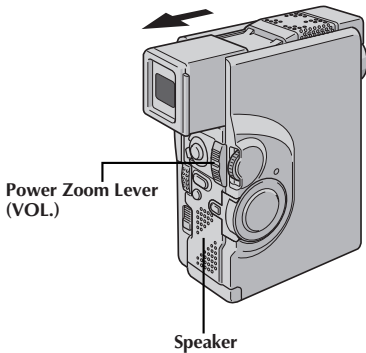
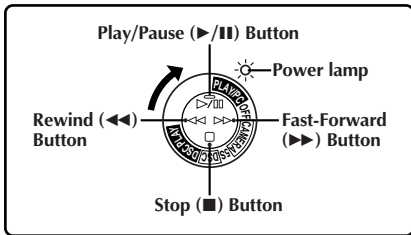
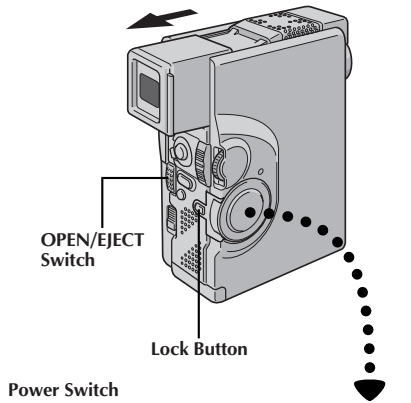

LCD monitor/Viewfinder Indication

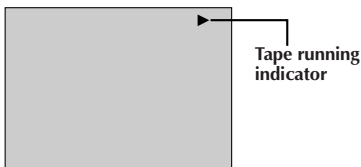

1 LOAD A CASSETTE

Slide **OPEN/EJECT** in the direction of the arrow, then swing the cassette cover open until it locks. The holder opens automatically. Insert a tape and press "PUSH HERE" to close the cassette holder.

2 SELECT OPERATION MODE

Set the Power Switch to "**PLAY/PC**" while pressing down the Lock Button. The power lamp lights.

3 PLAY BACK

Press ▶/⏸. The playback picture appears.

4 STOP PLAYBACK

Press ■.

Rewind or Fast-forward the tape

Press ◀◀ to rewind, or ▶▶ to fast-forward the tape during Stop mode.

NOTES:

- If Stop mode continues for 5 minutes when the power supply is a battery pack, the camcorder shuts off automatically. To turn on again, set the Power Switch to "OFF", then to "**PLAY/PC**".
- The playback picture can also be viewed in the viewfinder (with the viewfinder pulled out) or on a connected TV (☞ pg. 70, 71). Camcorder operation is the same as described in this section.
- You can also view the playback picture on the LCD monitor with it flipped over and retracted.
- LCD monitor/viewfinder indications:
 - When power is supplied from the battery pack: the "☐" battery pack remaining power indicator is displayed on the LCD monitor when it is turned on. When power is supplied through the DC cord: "☐" does not appear.
 - During Stop mode, none of the indications are displayed in the viewfinder.
- Copyguarded tapes cannot be played back. The screen displays a blue background.

Speaker (or Headphones) Volume Control

You can adjust the speaker (or headphones connected to the headphones connector) volume by pushing the Power Zoom Lever.

1 ADJUST VOLUME

If you want to turn up the volume . . .

.... slide the Power Zoom Lever (VOL.) towards "+".

If you want to turn down the volume . . .

.... slide the Power Zoom Lever (VOL.) towards "-".

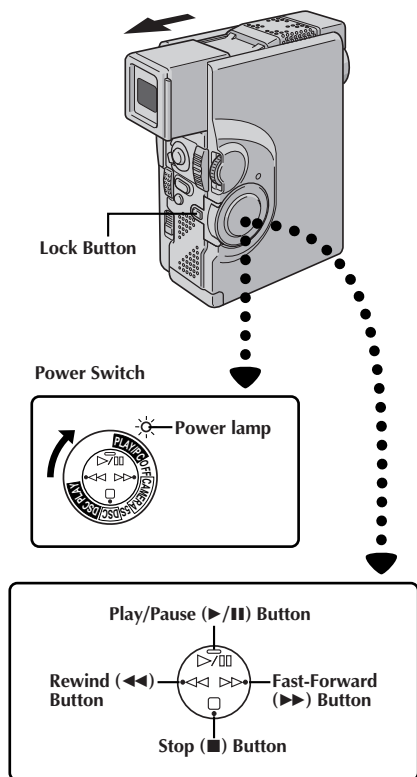

FEATURE: Still Playback

PURPOSE:

To pause during playback.

OPERATION:

- 1) Press ▶/⏸ during playback.
- 2) To resume normal playback, press ▶/⏸ again.

NOTES:

- If still playback continues for more than about 3 minutes, the camcorder's Stop mode is automatically engaged. After 5 minutes in the Stop mode, the camcorder's power is automatically turned off.
- When ▶/⏸ is pressed, the image may not pause immediately so that the camcorder can stabilise the still image. During this time, if PAUSE (⏸) on the remote control is pressed, Slow-Motion Playback will start. This is not a malfunction.

FEATURE: Shuttle Search

PURPOSE:

To allow high-speed search in either direction.

OPERATION:

- 1) Press ▶▶ to forward or press ◀◀ to reverse during playback.
- 2) To resume normal playback, press ▶/⏸.

NOTES:

- During playback, press and hold ◀◀ or ▶▶. The search continues as long as you hold the button. Once you release it, normal playback resumes.
- A slight mosaic effect appears on screen during Shuttle Search. This is not a malfunction.

FEATURE: Slow-Motion Playback

Available only with the RM-V713U remote control (provided) (☞ pg. 82).

FEATURE: Frame-By-Frame Playback

Available only with the RM-V713U remote control (provided) (☞ pg. 82).

FEATURE: Playback Zoom

Available only with the RM-V713U remote control (provided) (☞ pg. 82).

FEATURE: Playback Special Effects

Available only with the RM-V713U remote control (provided) (☞ pg. 83).

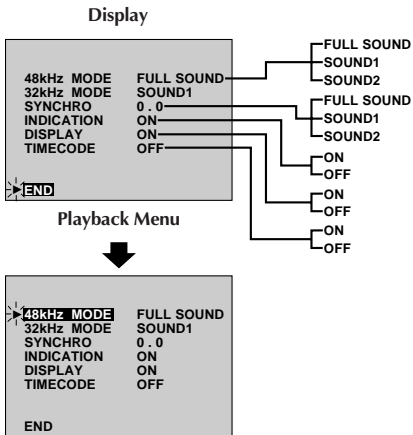
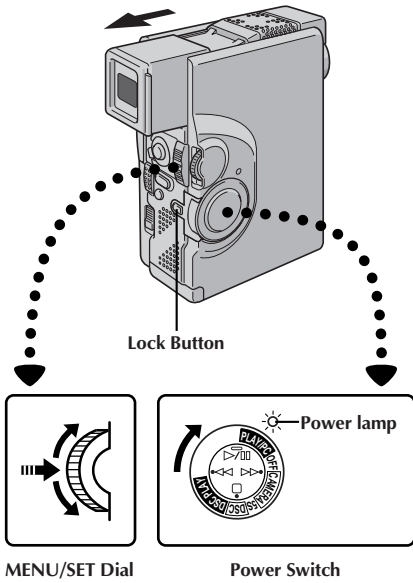

Playback Menu

The Playback Menu allows you to set the following functions:

Playback Sound (32 kHz, 48 kHz), Synchro Comp, Indication, Display and Time Code. The following procedure applies to all except *Synchro Comp* (☞ pg. 88, 89).

- 1 SELECT OPERATION MODE**
Set the Power Switch to "PLAY/PC" while pressing down the Lock Button. Pull out the viewfinder fully or open the LCD monitor fully.
- 2 ACCESS PLAYBACK MENU**
Press MENU/SET. The Playback Menu appears.
- 3 SELECT FUNCTION**
Move the highlight bar to the desired function by rotating MENU/SET. Press it to activate.
- 4 SET FUNCTION PARAMETERS**
Rotate MENU/SET to cycle through the available settings for the selected function, and stop when the desired setting appears. Then press MENU/SET, and the highlight bar automatically moves to "END".
 - To set parameters for other functions, repeat steps 3 and 4.
- 5 CLOSE MENU**
Press MENU/SET again, and the menu disappears.

Playback Sound

During playback, the camcorder detects the sound mode in which the recording was made, and plays the sound back. Select the type of sound to accompany your playback picture. (32 kHz is preset to "SOUND 1" and 48 kHz is preset to "FULL SOUND".)

Recording sound	Display	Output sound
32 kHz	FULL SOUND	Stereo sound
	SOUND 1	
	SOUND 2	
48 kHz	FULL SOUND	Stereo sound
	SOUND 1	"L" sound is output on both channels
	SOUND 2	"R" sound is output on both channels

When watching a tape recorded at 32 kHz, if you want to change the output sound, access the Playback Menu and, in step 3 on page 54, select "32 kHz MODE" and set it for "FULL SOUND", "SOUND 1" or "SOUND 2". When playing back a tape recorded at 48 kHz, set in the same manner.

NOTES:

- You can also use the provided RM-V713U remote control's **AUDIO MONITOR** button to change the output sound (without having to access the Playback Menu). Make sure you point the remote control at the camcorder's remote sensor.
- During playback, the camcorder detects the sound mode in which the recording was made. This detection cannot be made during fast-forward or rewind. During playback the sound mode is displayed in the upper left corner.

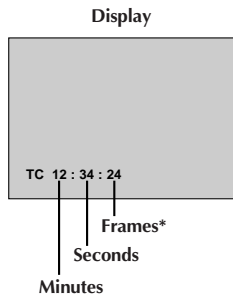

TIME CODE

(Displaying The Time Code During Playback)

You can display the Time Code on screen during playback. This is especially useful for editing. This function is preset to "OFF". To turn it on, select "TIME CODE" at the Playback Menu and change the setting (☞ pg. 54).

ON– The Time Code is displayed on the playback screen.

OFF– The Time Code does not appear.

DISPLAY (Displaying the Date During Playback)

If the time has been set, the date is automatically recorded separately from the recorded video signal. You can display or remove the date anytime during playback. This function is preset to "ON". To turn it off, select "DISPLAY" at the Playback Menu and change the setting (☞ pg. 54).

ON– The date is displayed on the playback screen.

OFF– The date is not displayed.

INDICATION

You can make the Playback Sound, Time Code and Date indications disappear. This function overrides the "TIME CODE" and "DISPLAY" settings in the Playback Menu. The factory-preset is "ON". To turn it off, select "INDICATION" in the Playback Menu and change the setting (☞ pg. 54).

OFF– The Playback Sound, Time Code and Date indications do not appear on the Playback Screen.

ON– The Playback Sound, Time Code and Date indications are displayed according to how "TIME CODE" and "DISPLAY" are set in the Playback Menu.

NOTE:

If "INDICATION" is set in the Date/Time Menu, "INDICATION" in the Playback Menu will also be set to the same setting (☞ pg. 34 – 38).

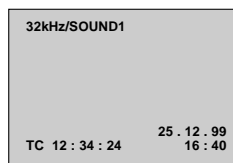
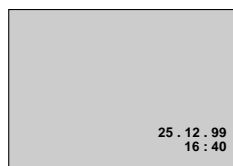

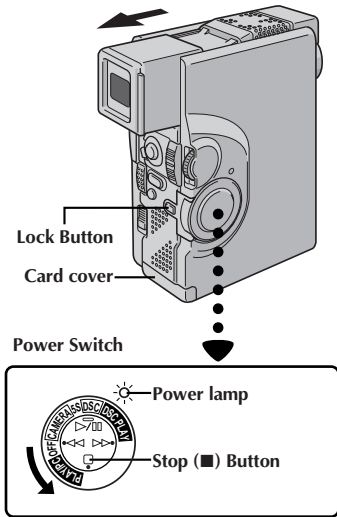

[For Normal Playback]
To display the next image

[For Auto Playback]

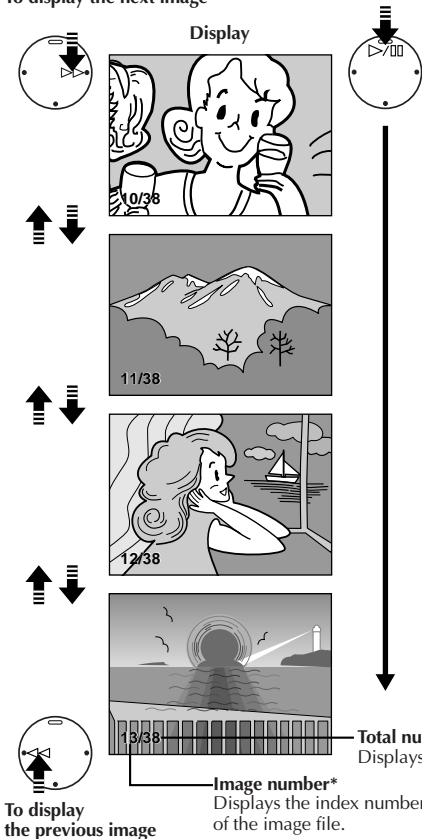

Normal Playback

Images shot with the camcorder are automatically numbered, then stored in numerical order in the MultiMediaCard. You can view the stored images, one at a time, much like flipping through a photo album.

1 LOAD A MULTIMEDIACARD

Open the card cover. Insert a MultiMediaCard, then close the card cover.

2 SELECT OPERATION MODE

Set the Power Switch to "DSC PLAY" while pressing down the Lock Button. Open the LCD monitor fully or pull out the viewfinder fully.

- A stored image is displayed.

3 DISPLAY ANOTHER IMAGE

Press ►► to display the next image.
Press ◄◄ to display the previous image.

Auto Playback

You can run through all the images stored in memory automatically.

1 LOAD A MULTIMEDIACARD

Open the card cover. Insert a MultiMediaCard, then close the card cover.

2 SELECT OPERATION MODE

Set the Power Switch to "DSC PLAY" while pressing down the Lock Button. Open the LCD monitor fully or pull out the viewfinder fully.

- A stored image is displayed.

3 START AUTO PLAYBACK

Press ►/II.

- If you press ◄◄ during Auto Playback, images are displayed in descending order.

- If you press ►► during Auto Playback, images are displayed in ascending order.

4 STOP AUTO PLAYBACK

Press ■.

NOTE:

Even if you shoot a new image after playing back a low-numbered one, this will not overwrite an existing image, because new images are automatically stored after the last-recorded one.

* Not displayed when "INDICATION" is set to "OFF" in the Date/Time Menu (⏏ pg. 38) or Video Playback Menu (⏏ pg. 55).

Slide Show

You can run through all the images stored in memory automatically in numerical order. Each still image wipes in over the last one from the bottom of the screen to the top.

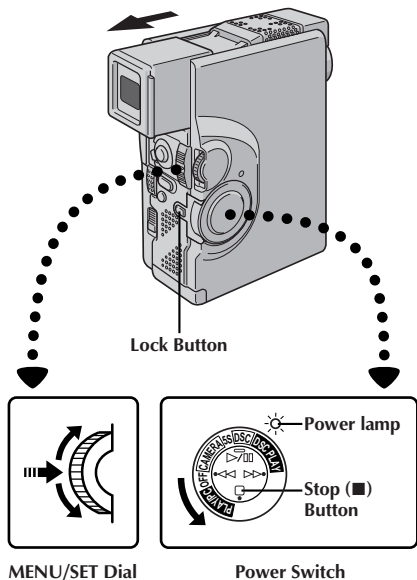

1 SELECT OPERATION MODE

Set the Power Switch to "DSC PLAY", while pressing down the Lock Button. Open the LCD monitor fully or pull out the viewfinder fully.

2 ACCESS PLAYBACK MENU

Press MENU/SET. The Playback Menu appears.

3 START SLIDE SHOW

Move the highlight bar to "SLIDE SHOW" by rotating MENU/SET, and press it. The Slide Show starts.

4 STOP SLIDE SHOW

Press ■.

NOTE:

While the Slide Show is being performed, the image may be disturbed.

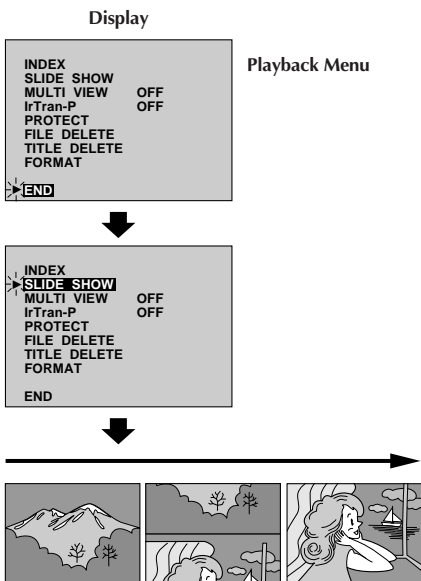

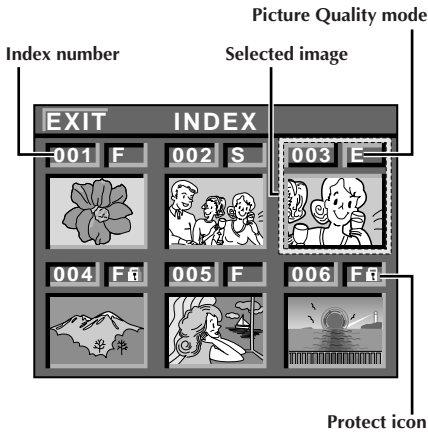

INDEX Screen

The images you shot can be displayed together with their index information. Convenient for checking images shot beforehand, the INDEX Screen also shows the Picture Quality mode as well as which images are protected against accidental erasure.

001: Index number

Index numbers are marked from 001. For example, when 10 images are stored (index number: 001 to 010), if three images with index numbers 002, 004 and 006 are deleted from memory, the remaining images are automatically moved up to fill any gaps in the numerical sequence. Therefore, the number of remaining images is 7, and the new index numbers range from 001 to 007.

F/S/E: Picture Quality mode

Displays the Picture Quality mode of the stored image. There are 3 modes available: FINE, STANDARD and ECONOMY (in order of quality).

: Protect icon

When an image is protected against its accidental erasure, a padlock mark appears next to the Picture Quality mode indicator, and that image cannot be deleted.

Selected Image

An image is framed in green when it is selected. Rotate MENU/SET to move the green frame to the desired image.

MENU/SET Dial

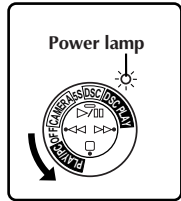
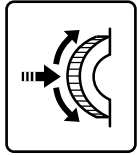

Power Switch

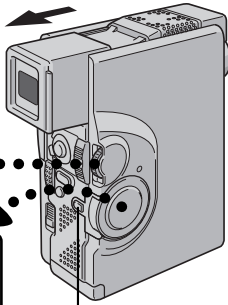

Lock Button

MULTI SCREEN Button

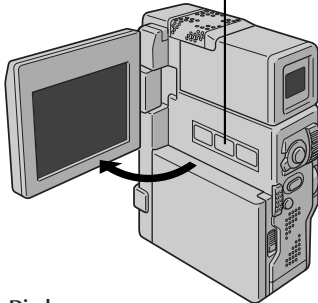

Display

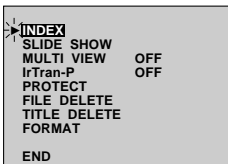

Playback Menu

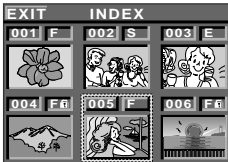

INDEX Screen



Playback Screen

Index Playback

You can view the images stored in memory six at a time. Use this mode when looking for an image you wish to view.

1 SELECT OPERATION MODE

Set the Power Switch to "DSC PLAY" while pressing down the Lock Button. Open the LCD monitor fully or pull out the viewfinder fully.

- A stored image is displayed.

2 ACCESS INDEX SCREEN

Press MULTI SCREEN. The INDEX Screen appears.

OR

Select "INDEX" in the Playback Menu (To access the Playback Menu, press MENU/SET).

3 DISPLAY DESIRED IMAGE

Rotate MENU/SET to move the green frame to the desired image and press it. The image selected in the INDEX Screen is displayed.

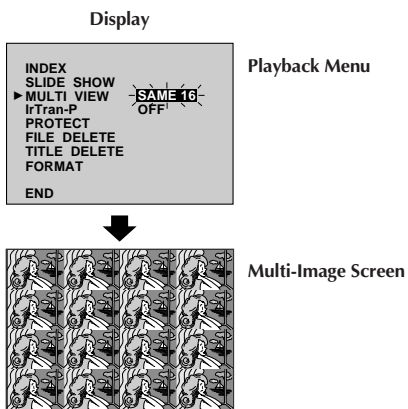
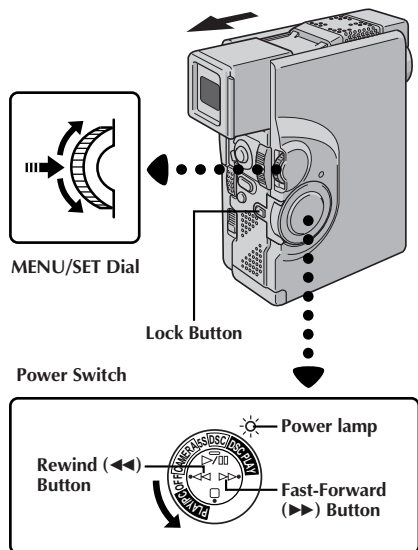

Multi-Image Screen

There are 3 Multi-Image Screens that can be created: 4-split screens composed of the same image, 16-split screens composed of the same image and 4-split screens composed of different, user-selected images.

1 SELECT OPERATION MODE

Set the Power Switch to "DSC PLAY" while pressing down the Lock Button. Open the LCD monitor fully or pull out the viewfinder fully.

- A stored image is displayed.
- To create a Multi-Image Screen using the same image, select an image before performing step 2.

2 ACCESS PLAYBACK MENU

Press MENU/SET. The Playback Menu appears.

3 SELECT FUNCTION

Rotate MENU/SET to move the highlight bar to "MULTI VIEW" and press it. The selected parameter blinks.

NOTES:

- By printing a Multi-Image Screen to a printer that supports sticker sheets, you can create stickers of any image you like. For details, read your printer's instruction manual.
- To create a Multi-Image Screen using the same image with a title/frame, first select the title/frame, referring to "Superimposing A Title/Frame" (pg. 69), and then go to step 2 above.
- If a title/frame is superimposed over the playback picture before step 2 is performed above, it will be impossible to set "MULTI VIEW" to "SELECTED 4".

TO CREATE A MULTI-IMAGE SCREEN USING THE SAME IMAGE

Before doing the following, perform steps 1 through 3 above.

4 SELECT MODE

Rotate MENU/SET until the "SAME 4" or "SAME 16" appears.

5 CREATE MULTI-IMAGE SCREEN

Press MENU/SET. A Multi-Image Screen displaying 4 or 16 frames of the same image appears.

6 END MULTI-IMAGE SCREEN

Set "MULTI VIEW" to "OFF" in the Playback Menu.

OR

Press ▶▶ or ◀◀ to display another image.

NOTE:

If you wish to change the still images which make up the Multi-Image Screen, go back to normal playback and change the "MULTI VIEW" setting in the Playback Menu.

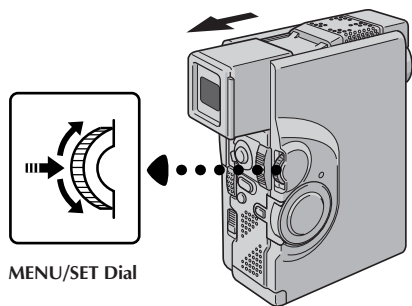

MENU/SET Dial

Display

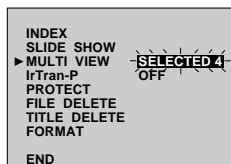

Playback Menu

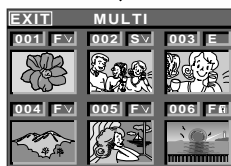

Multi-Image Index Screen

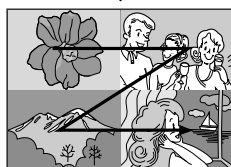

Multi-Image Screen

TO CREATE A MULTI-IMAGE SCREEN USING SELECTED IMAGES

Before doing the following, perform steps 1 through 3 (pg. 60).

4 SELECT MODE

Rotate **MENU/SET** until "SELECTED 4" appears and press it. The Multi-Image Index Screen appears.

5 SELECT IMAGES

Rotate **MENU/SET** to move the green frame to the desired image and press it. A check mark "✓" appears on the selected image. Repeat this procedure for all 4 images to be selected.

- To cancel the selection of an image, rotate **MENU/SET** to move the green frame to the desired image and press it. The check mark "✓" disappears.

6 CREATE MULTI-IMAGE SCREEN

Rotate **MENU/SET** upward to select "EXIT" and press it. The Multi-Image Screen of the selected images appears.

- The selected images are displayed in numerical order from left to right and top to bottom.
- If you exit before selecting all 4 images, the Multi-Image Screen is cancelled.

7 END MULTI-IMAGE SCREEN

Set "MULTI VIEW" to "OFF" in the Playback Menu.

OR

Press **▶▶** or **◀◀** to display another image.

NOTE:

If you wish to change the still images which make up the Multi-Image Screen, go back to normal playback and change the "MULTI VIEW" setting in the Playback Menu.

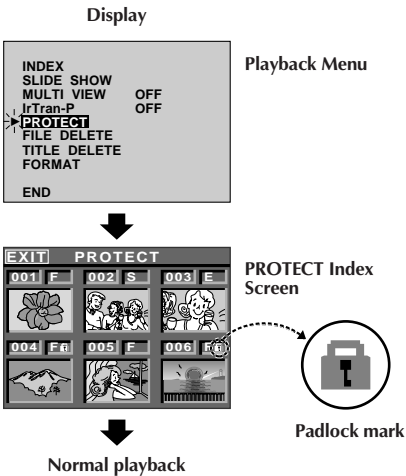
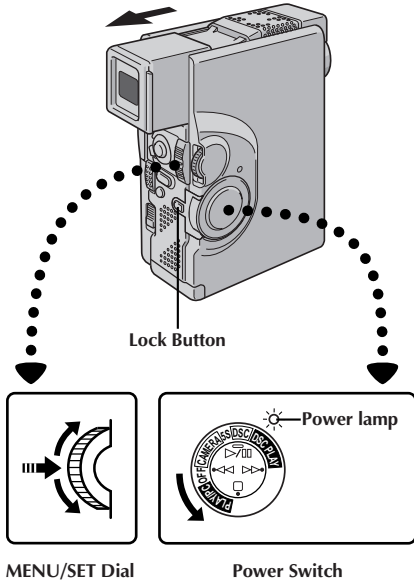

Protecting Images

The Protect mode helps prevent the accidental erasure of images. When a padlock mark is displayed next to the Picture Quality Mode indication, that image cannot be deleted.

1

SELECT OPERATION MODE

Set the Power Switch to "DSC PLAY" while pressing down the Lock Button. Open the LCD monitor fully or pull out the viewfinder fully.

- A stored image is displayed.

2

ACCESS PLAYBACK MENU

Press MENU/SET. The Playback Menu appears.

3

SELECT FUNCTION

Rotate MENU/SET to move the highlight bar to "PROTECT" and press it. The PROTECT Index Screen appears.

TO PROTECT AN IMAGE

Before doing the following, perform steps 1 through 3 above.

4

SELECT IMAGE

Rotate MENU/SET to move the green frame to the desired image and press it. A "🔒" padlock mark appears on the selected image.

Repeat this procedure for all images you do not wish to delete by accident.

5

END SELECTION

Rotate MENU/SET upward to select "EXIT" and press it. The normal playback screen appears.

NOTE:

When the memory is initialised or corrupted, even protected images are deleted. If you do not want to lose important images, we recommend you to transfer them to a PC and save them.

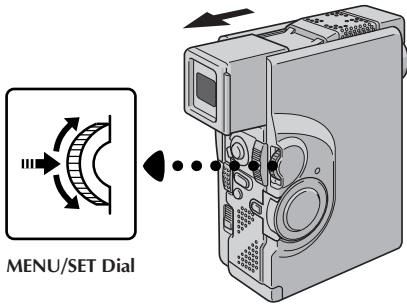

Display

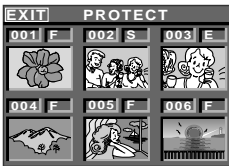
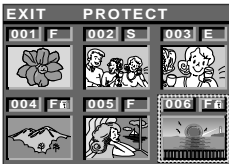

Normal playback

TO REMOVE PROTECTION

Before doing the following, perform steps 1 through 3 (pg. 62).

4 SELECT IMAGES

Rotate MENU/SET to move the green frame to the desired image and press it. The “” padlock mark located above the image disappears and the image is no longer protected.

Repeat this procedure for all images from which you wish to remove protection.

5 END PROTECTION

Rotate MENU/SET upward to select “EXIT” and press it. The normal playback screen appears.

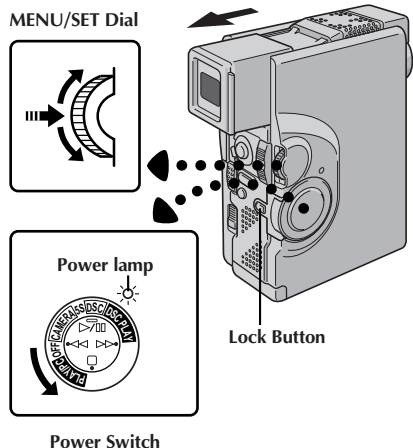

Display

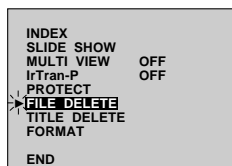

Playback Menu

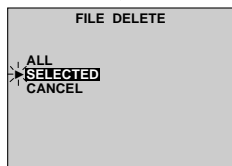

FILE DELETE Screen

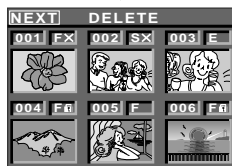

DELETE Index Screen

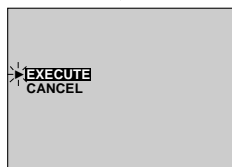

Deletion Confirmation Screen



Normal playback

Deleting Images

Previously shot images can be deleted either one at a time or all at once.

1 SELECT OPERATION MODE

Set the Power Switch to "DSC PLAY" while pressing down the Lock Button. Open the LCD monitor fully or pull out the viewfinder fully.

- A stored image is displayed.

2 ACCESS PLAYBACK MENU

Press MENU/SET. The Playback Menu appears.

3 SELECT FUNCTION

Rotate MENU/SET to move the highlight bar to "FILE DELETE" and press it. The FILE DELETE Screen appears.

TO SELECT AN IMAGE BY BROWSING IMAGES STORED IN MEMORY

Before doing the following, perform steps 1 through 3 above.

4 SELECT MODE

Rotate MENU/SET to select "SELECTED" and press it. The DELETE Index Screen appears.

5 SELECT IMAGE

Rotate MENU/SET to move the green frame to the desired image that you wish to delete and press it. An "X" appears above the selected image.

Repeat this procedure for all images that you wish to delete.

To deselect an image, press MENU/SET again. The "X" disappears.

6 END SELECTION

Rotate MENU/SET upward to select "NEXT" and press it. The Deletion Confirmation Screen appears.

7 DELETE IMAGE

Rotate MENU/SET to select "EXECUTE" and press it. The selected images are deleted and the normal playback screen appears.

- If you wish to cancel deletion, rotate MENU/SET to select "CANCEL" and press it.

CAUTION:

While deleting images, never remove the MultiMediaCard or disconnect power, as this may cause the memory to be corrupted. Also, be sure to use the AC Power Adapter/Charger, as a malfunction may occur if the battery become exhausted halfway through the operation.

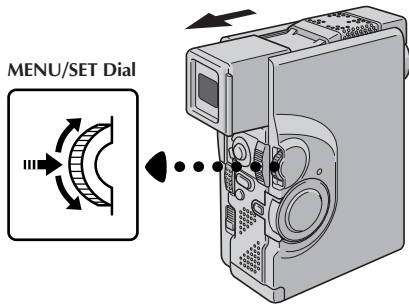

TO DELETE ALL IMAGES

Before doing the following, perform steps 1 through 3 (pg. 64).

4 SELECT MODE

Rotate **MENU/SET** to select "ALL" and press it. The Deletion Confirmation Screen appears.

5 DELETE IMAGES

Rotate **MENU/SET** to select "EXECUTE" and press it. All the images are deleted.

- If you wish to cancel deletion, rotate **MENU/SET** to select "CANCEL" and press it.

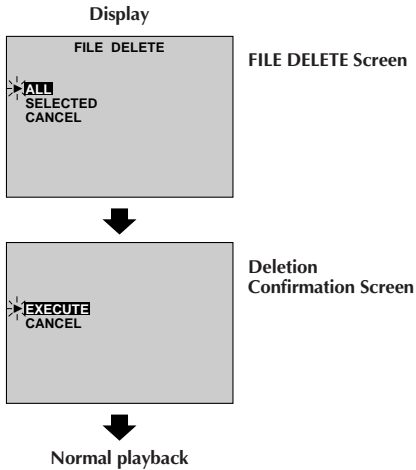

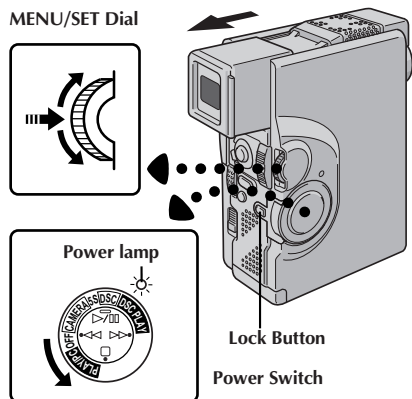

Display

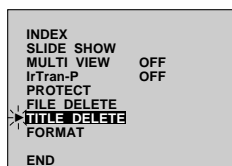

Playback Menu

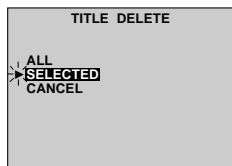

TITLE DELETE Screen



DELETE Index Screen

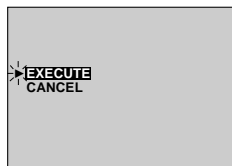

Deletion Confirmation Screen

Normal playback

Deleting Titles/Frames

A title/frame created on a PC can be transferred to a MultiMediaCard using the provided software. Titles/frames that have been transferred to a MultiMediaCard can be deleted when they are no longer needed.

There are 2 ways of deleting previously created titles/frames: by browsing through titles/frames individually or by deleting them all at once.

1 SELECT OPERATION MODE

Set the Power Switch to "DSC PLAY" while pressing down the Lock Button. Open the LCD monitor fully or pull out the viewfinder fully.

- A stored image is displayed.

2 ACCESS PLAYBACK MENU

Press MENU/SET. The Playback Menu appears.

3 SELECT FUNCTION

Rotate MENU/SET to move the highlight bar to "TITLE DELETE" and press it. The TITLE DELETE Screen appears.

NOTES:

- If titles/frames created on a PC have not been transferred to a MultiMediaCard, it is not possible to delete them using these steps.
- The titles/frames in the camcorder's memory cannot be deleted.

TO SELECT A TITLE/FRAME BY BROWSING TITLES/FRAMES STORED IN MEMORY

Before doing the following, perform steps 1 through 3 above.

4 SELECT MODE

Rotate MENU/SET to select "SELECTED" and press it. The DELETE Index Screen appears.

5 SELECT TITLE/FRAME

Rotate MENU/SET to move the green frame to the desired title/frame that you wish to delete and press it. An "X" appears above the selected title/frame. Repeat this procedure for all titles/frames that you wish to delete.

To deselect a title/frame, press MENU/SET again. The "X" disappears.

6 END SELECTION

Rotate MENU/SET upward to select "NEXT" and press it. The Deletion Confirmation Screen appears.

7 DELETE TITLE/FRAME

Rotate MENU/SET to select "EXECUTE" and press it. The selected titles/frames are deleted and the normal playback screen appears.

- If you wish to cancel deletion, rotate MENU/SET to select "CANCEL" and press it.

CAUTION:

While deleting titles/frames, never remove the MultiMediaCard or disconnect power, as this may cause the memory to be corrupted. Also, be sure to use the AC Power Adapter/Charger, as a malfunction may occur if the battery become exhausted halfway through the operation.

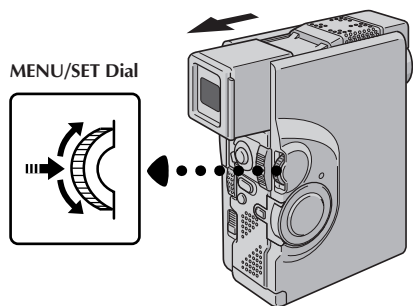

TO DELETE ALL TITLES/FRAMES

Before doing the following, perform steps 1 through 3 (pg. 66).

4 SELECT MODE

Rotate **MENU/SET** to select "ALL" and press it. The Deletion Confirmation Screen appears.

5 DELETE TITLE/FRAME

Rotate **MENU/SET** to select "EXECUTE" and press it. All the titles/frames are deleted.

- If you wish to cancel deletion, rotate **MENU/SET** to select "CANCEL" and press it.

Display



TITLE DELETE Screen

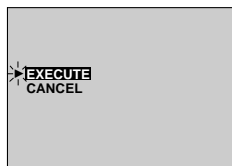

Deletion Confirmation Screen



Normal playback

Types Of Titles/Frames

This camcorder has 12 preset titles/frames stored in its memory, as shown in the following illustration.

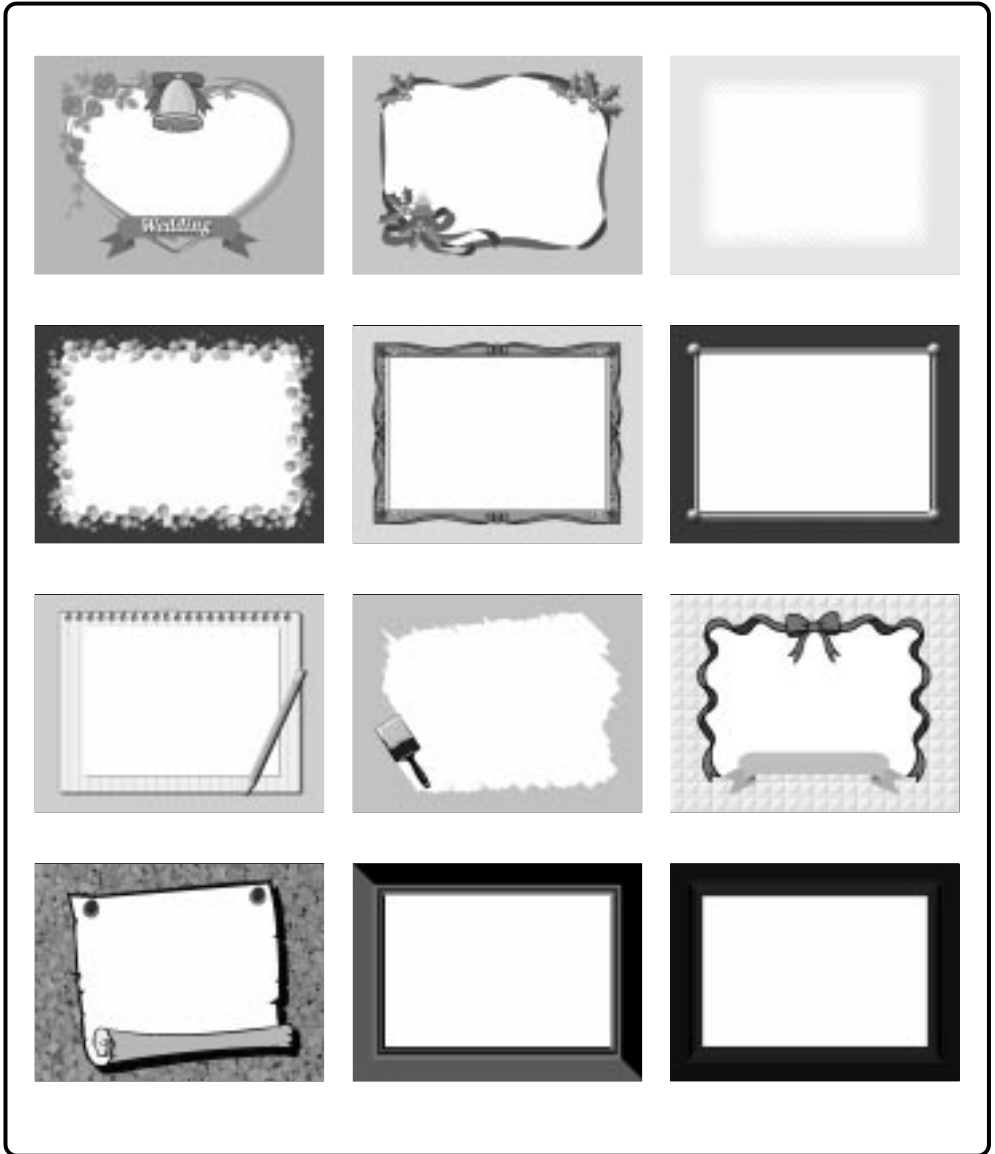

Operation Switch

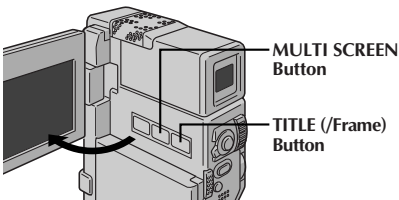
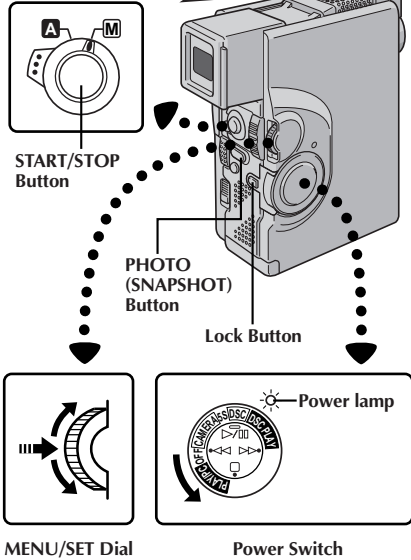

Display



Superimposing A Title/Frame

A title/frame can be superimposed over the playback picture (image).

- 1 START PLAYBACK**
Play back a tape or images in a MultiMediaCard.
- 2 SUPERIMPOSE TITLE/FRAME**
Press **TITLE (/Frame)**. A title/frame is superimposed over the playback picture (image).
- 3 ACCESS TITLE/FRAME INDEX SCREEN**
Press **MULTI SCREEN**. The Title/Frame Index Screen appears.
- 4 SELECT DESIRED TITLE/FRAME**
Rotate **MENU/SET** to move the green frame to the desired title/frame and press it. The selected title/frame is superimposed over the playback picture (image).
- 5 MAKE TITLE/FRAME DISAPPEAR**
Press **TITLE (/Frame)**. The selected title/frame disappears.

NOTES:

- A title/frame created on a PC can be transferred to a MultiMediaCard using the provided software. Transferred titles/frames are displayed from title/frame index number 013, and they can be used together with the titles/frames in the camcorder's memory. For details on creating/transferring titles/frames, refer to the software instructions.
- If Snapshot recording/playback is performed with a title/frame, the images will be recorded/played back in the FULL mode regardless of the selected Snapshot mode.
- Depending on the images you record or play back, the title/frame outline may become grainy or vague.
- During title/frame display, it is not possible to change the Snapshot mode.

To Record An Image With A Title/Frame . . .

- You can also record an image with a title/frame by performing the following procedure.
1. Set the Operation Switch to "**A**" or "**M**". Then, set the Power Switch to "**CAMERA**", "5S" or "**DSC**" while pressing down the Lock Button.
 2. Press **TITLE (/Frame)** to superimpose a title/frame on an image.
 3. Press **MULTI SCREEN** to display the Title/Frame Index Screen.
 4. Rotate **MENU/SET** to move the green frame to the desired title/frame and press it. The selected title/frame is superimposed over the image.
 5. Press **START/STOP** or **PHOTO (SNAPSHOT)** to start recording. The image is recorded with the selected title/frame.
 6. Press **TITLE (/Frame)** to make the title/frame disappear.

NOTES:

- During recording, it is not possible to change the title/frame, as the Title/Frame Index Screen does not appear if **MULTI SCREEN** is pressed.
- The titles/frames displayed in the Title/Frame Index Screen may be jittery.

These are some basic types of connections. When making the connections, refer also to your VCR and TV instruction manuals.

A. Connection to a TV or VCR equipped with an S-VIDEO IN and A/V input (RCA type) connectors

Use the provided Docking Station, Audio/Video (A/V) cable [RCA plug to RCA plug] and S-Video cable.

Docking Station Attachment

- Align the edge of the camcorder **(A)** with the edge of the Docking Station **(B)**.
 - Align the direction stud and screw on the Docking Station with the stud hole and tripod mounting socket on the camcorder.
 - Tighten the screw.
- When removing the camcorder, loosen the screw and detach the camcorder.

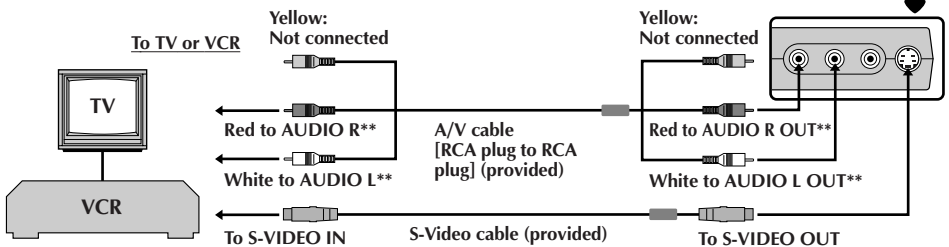
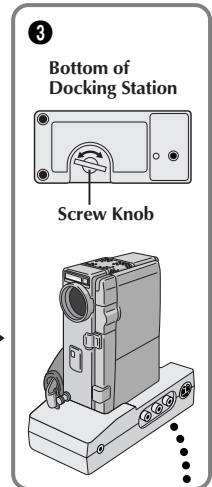
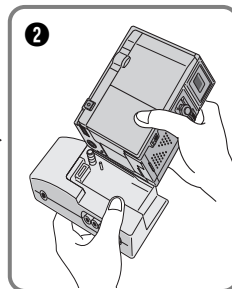
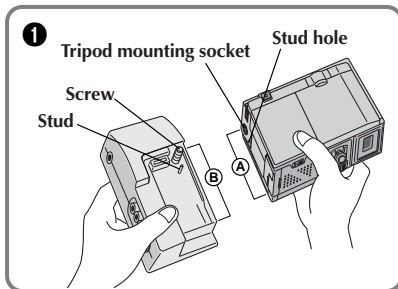

** The Audio cable is not required for watching still images with the Power Switch set to "DSC PLAY".

B. Connection to a TV or VCR equipped only with A/V input connectors

Use the provided Audio/Video (A/V) cable [mini-plug to RCA plug].

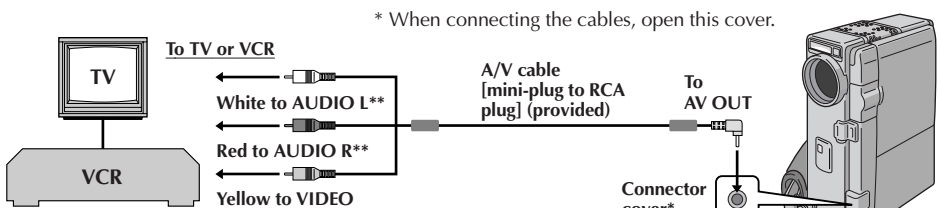

* When connecting the cables, open this cover.

** The Audio cable is not required for watching still images with the Power Switch set to "DSC PLAY".

1 CONFIRM POWER-OFF STATUS

Make sure the camcorder's power is off.

2 CONNECT CAMCORDER TO TV OR VCR

Connect as shown in the illustration (☞ pg. 70).

If Using A VCR . . . go to step 3.

If not . . . go to step 4.

3 CONNECT VCR OUTPUT TO TV INPUT

Refer to your VCR's instruction manual.

4 SUPPLY POWER

Turn on the camcorder, the VCR and the TV.

5 SELECT MODE

Set the VCR to its AUX input mode, and set the TV to its VIDEO mode.

To choose whether or not the following displays appear on the connected TV . . .

- Date/Time, Time Code
.... set to "ON" or "OFF" in the Playback Menu (☞ pg. 54).
- Playback Sound Mode Display
.... set the Operation Switch to "M", then set the Power Switch to the camera position ("CAMERA", "5S" or "DSC") while pressing down the Lock Button. Press **MENU/SET** and set "ON SCREEN" in the Date/Time Menu (☞ pg. 34 – 38) to "ON" or "OFF". Then, set the Power Switch back to "PLAY/PC".

NOTES:

- *It is recommended to use the AC Power Adapter/Charger as the power supply instead of the battery pack.* (☞ pg. 9)
- *Never connect any other Audio/Video cable than the provided Audio/Video cable (mini-plug to RCA plug) to the camcorder's AV OUT connector.*
- *When using the cables (except Audio/Video cable with mini-plug to RCA plug), make sure you connect the end of the cable with the core filter to the camcorder. The core filter reduces interference.*
- *To monitor the picture and sound from the camcorder without inserting a tape, set the camcorder's Power Switch to "CAMERA", "5S" or "DSC", then set your TV to the appropriate input mode.*
- *Make sure you adjust the TV sound volume to its minimum level to avoid a sudden burst of sound when the camcorder is turned on.*
- *If you have a TV or speakers that are not specially shielded, do not place the speakers adjacent to the TV as interference will occur in the camcorder playback picture.*
- *To keep the camcorder's display from appearing on the TV screen during playback, set "INDICATION" to "OFF" in the Playback Menu (☞ pg. 54) and press **DISPLAY** on the remote control.*
- *While the Audio/Video cable is connected to the AV OUT connector, sound cannot be heard from the speaker.*

PC with DV connector-
equipped capture board



PC

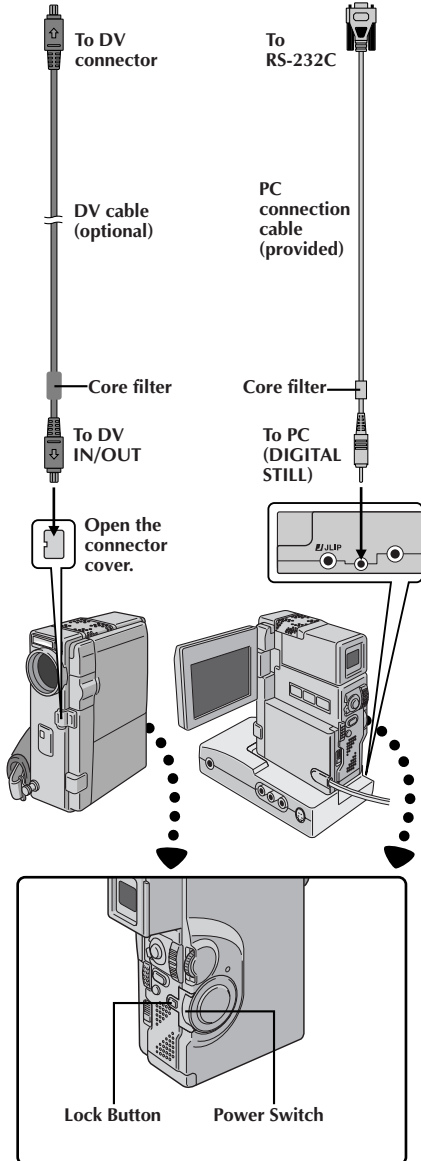

Connection To A Personal Computer

This camcorder can transfer still images to a personal computer by using the provided software when connected as shown in the illustration. It is also possible to transfer still images to a personal computer with a DV connector-equipped capture board installed.

1 CONFIRM POWER-OFF STATUS

Make sure the camcorder and PC are turned off.

2 CONNECT TO PC

Connect the camcorder or Docking Station to your PC using the appropriate cable as shown in the illustration.

- To attach the camcorder to Docking Station, refer to "Docking Station Attachment" on pg. 70.

3 TURN ON POWER

Turn the camcorder's Power Switch to "PLAY/PC" while pressing down the Lock Button and turn on the PC.

NOTES:

- *It is recommended to use the AC Power Adapter/Charger as the power supply instead of the battery pack (pg. 9).*
- *Never connect the PC connection cable and the DV cable simultaneously to the camcorder. Connect only the cable you wish to use to the camcorder.*
- *The date/time information cannot be captured into PC.*
- *Also refer to the instruction manuals of the provided Software and the DV connector-equipped capture board.*
- *Be sure to use a DV cable with the core filter.*

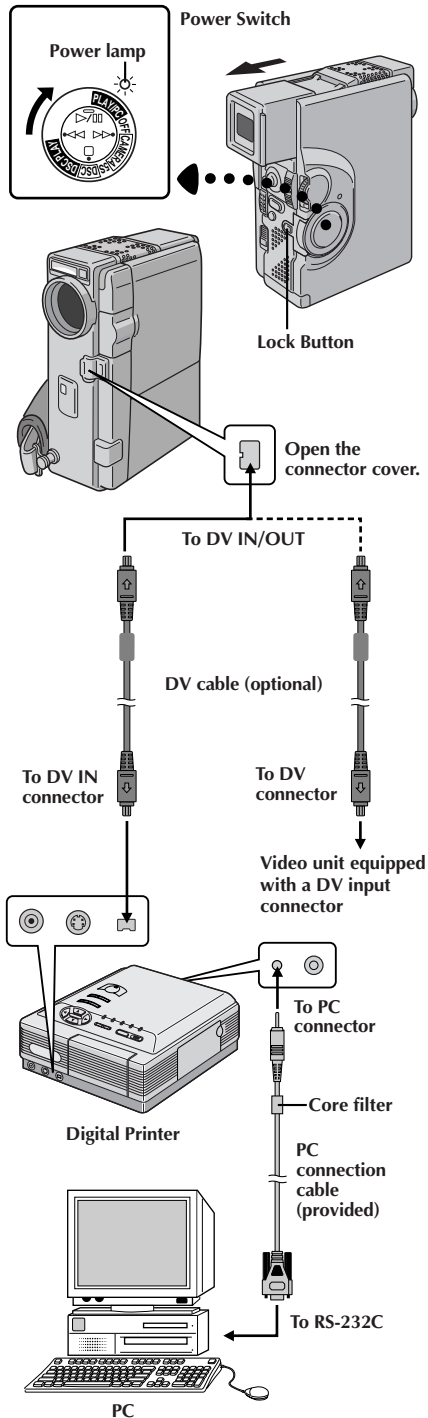

Connection To A Video Unit Equipped With A DV Connector

Connection to the Digital Printer GV-DT3 (optional) allows you to print out the images or to transfer the captured image from the Digital Printer to a personal computer. It is also possible to copy recorded scenes from the camcorder onto another video unit equipped with a DV connector. This function is called Digital Dubbing (see pg. 75), which offers virtually no image or sound deterioration.

1 CONFIRM POWER-OFF STATUS

Make sure all the units are turned off.

2 CONNECT CAMCORDER TO PRINTER OR VIDEO UNIT EQUIPPED WITH DV INPUT CONNECTOR

Make connections to the device you want to connect to using the DV cable, as shown in the illustration.

3 CONNECT PRINTER TO PC (IF NECESSARY)

Connect the PC connection cable (provided) to the printer's PC connector and the PC's RS-232C connector.

4 TURN ON POWER

Turn the camcorder's Power Switch to "PLAY/PC" while pressing down the Lock Button and turn on the other units.

NOTES:

- It is recommended to use the AC Power Adapter/Charger as the power supply instead of the battery pack. (see pg. 9)
- For Digital Dubbing, this camcorder can be connected only to one device at a time. This camcorder can also be used as a recorder.
- If Still Playback, Slow-Motion Playback, Fast-Forward or Rewind is attempted with the camcorder connected to a video unit via the DV connector, the image will take on an effect similar to a coloured mosaic pattern or it will become black.
- Also refer to the instruction manuals of the connected units.
- Be sure to use a DV cable with the core filter.

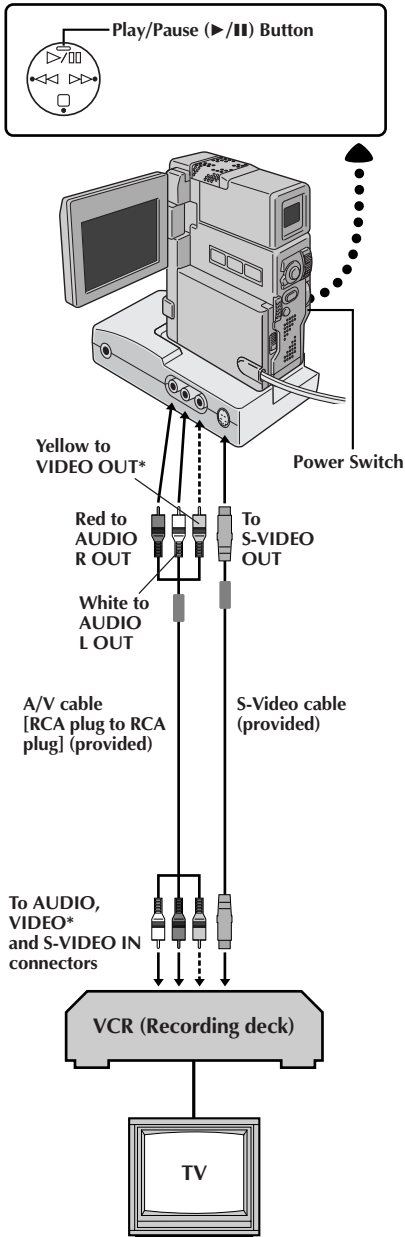

Dubbing Images/Sounds Recorded On A Tape To Another Tape

- 1 CONNECT EQUIPMENT**
Following the illustration at left, connect the camcorder and the VCR. Also refer to pg. 70 and 71.
- 2 PREPARE FOR DUBBING**
Set the camcorder's Power Switch to "PLAY/PC", turn on the VCR's power, and insert the appropriate cassettes in the camcorder and the VCR.
- 3 SELECT VCR MODE**
Engage the VCR's AUX and Record-Pause modes.
- 4 FIND EDIT-IN POINT**
Engage the camcorder's Play mode to find a spot just before the edit-in point. Once it is reached, press ▶/⏸ on the camcorder.
- 5 START EDITING**
Press ▶/⏸ on the camcorder and engage the VCR's Record mode.
- 6 STOP EDITING TEMPORARILY**
Engage the VCR's Record-Pause mode and press ▶/⏸ on the camcorder.
- 7 EDIT MORE SEGMENTS**
Repeat steps 4 through 6 for additional editing, then stop the VCR and camcorder when finished.

NOTES:

- You can use the AV OUT connector on the camcorder for connection.
- You can use Playback Zoom (☞ pg. 82) or Playback Special Effects (☞ pg. 83) in step 5.
- Before you start dubbing, make sure that the indications do not appear on the connected TV. If they do appear during dubbing, they are being recorded onto the new tape.
To clear the Playback Sound Mode Display, press **DISPLAY** on the RM-V713U remote control (provided).
- Select "DISPLAY" and "TIME CODE" from the Playback Menu (☞ pg. 54) to show or hide the Date/Time and the Time Code on the recording.
- To keep all the camcorder's indications from appearing on the VCR, set "INDICATION" to "OFF" in the Playback Menu (☞ pg. 54) and press **DISPLAY** on the remote control.

* Connect when the S-Video cable is not used.

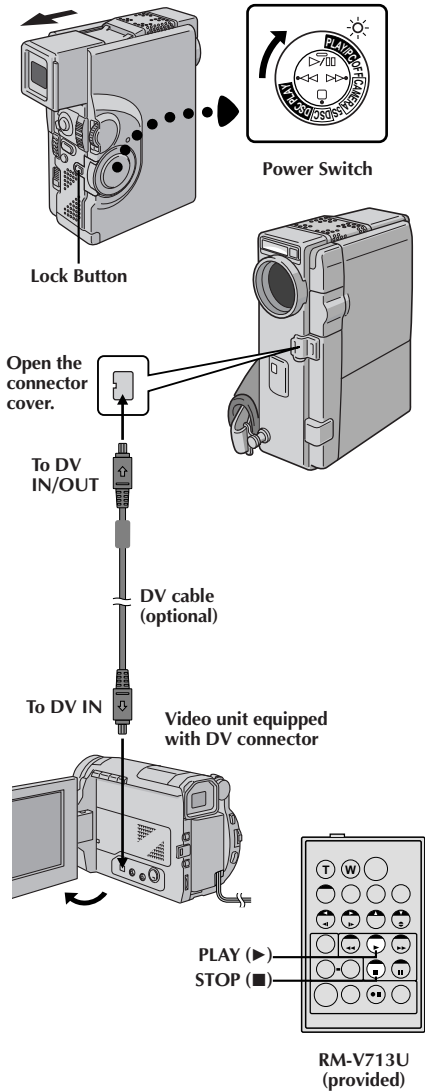

Digital Dubbing Of Recorded Images/Sounds Between Tapes

It is also possible to copy recorded scenes from the camcorder onto other video unit equipped with a DV connector. Since a digital signal is sent, there is little if any image or sound deterioration.

1 CONFIRM POWER-OFF STATUS

Make sure the camcorder's power is off.

2 MAKE CONNECTIONS

Connect the camcorder to your video unit equipped with a DV connector using the DV cable (optional) as shown in the illustration.

3 START PLAYBACK

Press ▶ to play back the source tape.

4 START RECORDING

While watching the playback on the monitor, engage the DV connector-equipped video unit's record mode from the spot on the source tape you want to begin recording.

NOTES:

- *It is recommended to use the AC Power Adapter/Charger as the power supply instead of the battery pack (☞ pg. 9).*
- *If the remote control is used when both the player and recorder are JVC video units, both units will perform the same operation. To prevent this from happening, press the buttons on both units.*
- *For Digital Dubbing, this camcorder can be connected only to one device at a time. This camcorder can also be used as a recorder.*
- *If a blank portion or disturbed image is played back on the player during dubbing, the dubbing may stop so that an unusual image is not dubbed.*
- *Even though the DV cable is connected correctly, sometimes the image may not appear in step 3. If the above occurs, turn off power and make connections again.*
- *If "Playback Zoom" (☞ pg. 82), "Playback Special Effects" (☞ pg. 83), "Superimposing A Title/Frame" (☞ pg. 69) or "Snapshot" is attempted during playback, only the original playback image recorded on the tape is output from the DV IN/OUT connector.*
- *Be sure to use a DV cable with the core filter.*

To Use This Camcorder As A Recorder . . .

1. Turn the Power Switch to "PLAY/PC" while pressing down the Lock Button.
2. Connect the DV cable as shown in the illustration and load a cassette to record on.
3. Press the Recording Start/Stop Button to engage the Record-Pause mode. "DV IN" appears on the screen.
4. Press the Recording Start/Stop Button to start recording. "DV IN" changes to "DV IN".
5. Press the Recording Start/Stop Button again to engage the Record-Pause mode. "DV IN" returns to "DV IN".

NOTES:

- *During Digital Dubbing, the image is dubbed using the recording mode selected in the Mode Menu (☞ pg. 13).*
- *Digital Dubbing is performed in the sound mode recorded on the original tape, regardless of the current "SOUND MODE" setting (☞ pg. 39).*
- *During Digital Dubbing, no signal is output from the AV OUT connector.*

Dubbing Images Recorded On A Tape To A MultiMediaCard

Images can be dubbed from a tape to a MultiMediaCard.

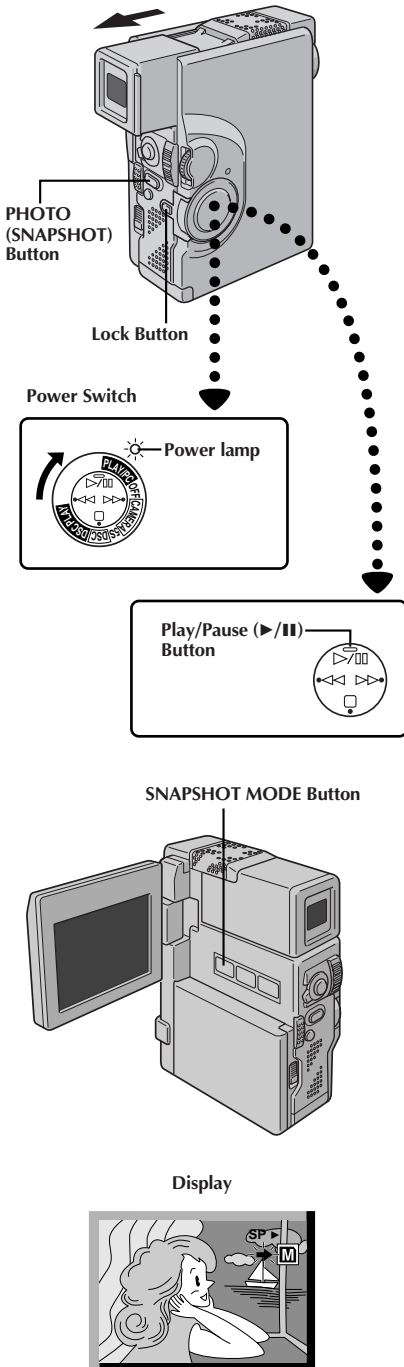

1 LOAD CASSETTE AND MULTIMEDIACARD

2 SELECT OPERATION MODE

Set the Power Switch to "PLAY/PC" while pressing down the Lock Button. Open the LCD monitor fully or pull out the viewfinder fully.

3 SELECT IMAGE TO BE DUBBED

Press ▶/|| to start playback. At the moment you find the image you wish to dub, press it again to engage Still Playback.

4 SELECT SNAPSHOT MODE

Press SNAPSHOT MODE to select the Snapshot mode to use for dubbing the image to the MultiMediaCard.

5 START COPYING

Press PHOTO (SNAPSHOT). The image is stored in the MultiMediaCard.

• "▶" blinks during dubbing.

NOTES:

- If **PHOTO (SNAPSHOT)** is pressed in step 5 when a MultiMediaCard is not loaded, the message "COPYING FAILED" is displayed.
- If an image recorded on the tape using the **WIDE** mode (pg. 37) is dubbed to a MultiMediaCard, the **WIDE** mode identifying signal is not dubbed with it.

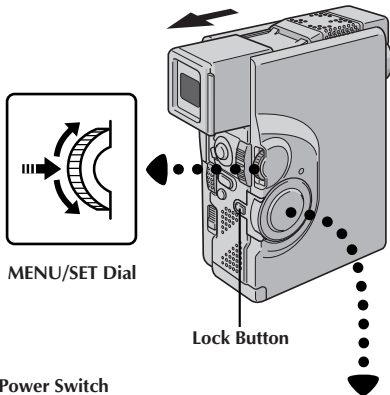

MENU/SET Dial

Lock Button

Power Switch

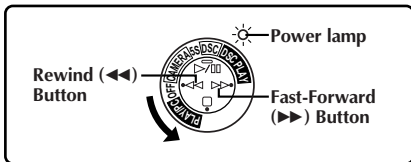

Infrared transmitter/receiver

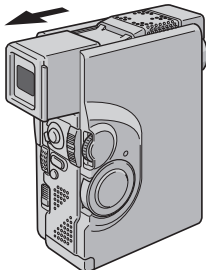
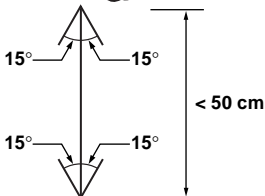
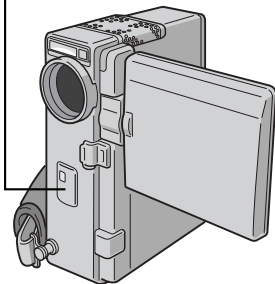

Copying Images Using Infrared Communication [IrTran-P]

Images stored in a MultiMediaCard can be copied between this camcorder and another piece of equipment that supports IrDA (IrTran-P) infrared communication, regardless of its manufacturer.

The following procedure is described using two GR-DVX7 camcorders as an example. For use of other video units, refer to their respective instructions.

- 1 LOAD MULTIMEDIACARDS**
 [For both receiving and transmitting camcorders]
 Insert MultiMediaCards into both receiving and transmitting camcorders.
- 2 SELECT OPERATION MODE**
 [For both receiving and transmitting camcorders]
 Set the Power Switch to "DSC PLAY" while pressing down the Lock Button. Open the LCD monitor fully or pull out the viewfinder fully.
- 3 ACCESS PLAYBACK MENU**
 [For both receiving and transmitting camcorders]
 Press MENU/SET. The Playback Menu appears.
- 4 SELECT FUNCTION**
 [For both receiving and transmitting camcorders]
 Rotate MENU/SET to move the highlight bar to "IrTran-P" and press it. The selected parameter blinks.
- 5 SELECT IrTran-P MODE**
 [For transmitting camcorder]
 Rotate MENU/SET until "TRANSMIT" appears and press it. The normal playback screen appears.
- 6 SELECT IMAGE TO BE COPIED**
 [For transmitting camcorder]
 Perform Index Playback (⏮ pg. 59), Auto Playback (⏪ pg. 56) or press ◀ or ▶ to select the desired image.

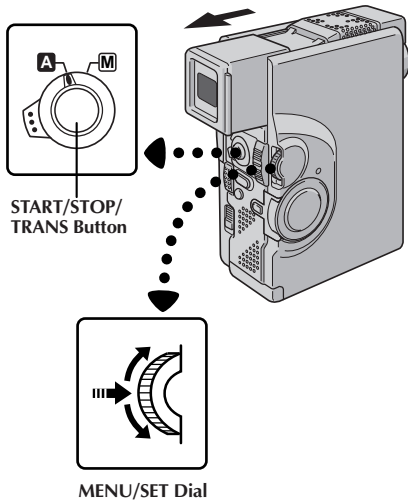

7 POSITION CAMCORDERS

[For both receiving and transmitting camcorders]

Position the transmitting and receiving camcorders so that their infrared transmitter and receiver face each other.

- The distance between them should be less than 50 cm and the transmitter and receiver should be angled no more than 15° to each other.

8 TRANSMIT IMAGE

[For transmitting camcorder]

Press **START/STOP/TRANS**. Image transmission starts and the message "IN PROGRESS" is displayed.

9 RECEIVE IMAGE

[For receiving camcorder]

Rotate **MENU/SET** until "RECEIVE" appears and press it. Image reception starts and the message "IN PROGRESS" is displayed. Reception is complete when the message disappears.

NOTES:

- Be sure to supply power from the AC Power Adapter/Charger instead of the battery pack.
- [For transmitting camcorder]
 - Be sure to set "IrTran-P" back to "OFF" when the transmission is finished.
 - An image with a title/frame can also be transmitted.
 - If the message "COMMUNICATION FAILED" is displayed within approx. 60 seconds after **START/STOP/TRANS** is pressed, check the equipment orientation, power supplies, etc. and retry the transmission.
 - To abort transmission in the middle, press **START/STOP/TRANS**. The message "COMMUNICATION FAILED" is displayed.
- [For receiving camcorder]
 - If the message "COMMUNICATION FAILED" is displayed, check the equipment orientation, power supply, etc. and retry the transmission.
 - "IrTran-P" automatically returns to "OFF" when the reception is complete or it fails.

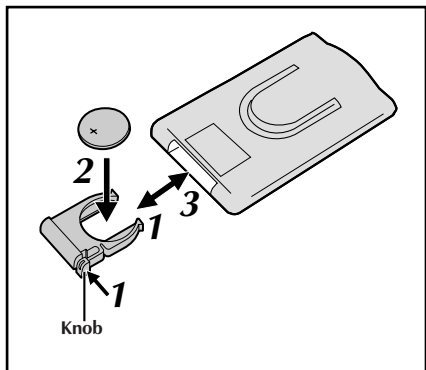

The Full-Function Remote Control Unit can operate this camcorder from a distance as well as the basic operations (Playback, Stop, Pause, Fast-Forward and Rewind) of your VCR. This remote control unit makes additional playback functions possible.

Installing The Battery

The remote control uses one lithium battery (CR2025).

1 PULL OUT BATTERY HOLDER

Pull out the battery holder while pressing the knob as shown.

2 INSERT BATTERY IN HOLDER

Insert the battery in the holder, and be sure to have the "+" mark visible.

3 RE-INSERT HOLDER

Slide the holder back in until you hear a click.

- Read the caution concerning lithium batteries (☞ pg. 2).

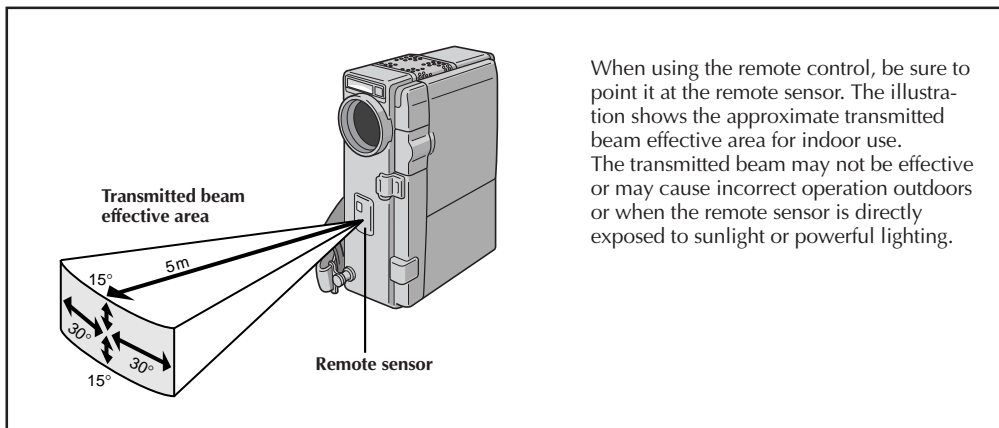

When using the remote control, be sure to point it at the remote sensor. The illustration shows the approximate transmitted beam effective area for indoor use. The transmitted beam may not be effective or may cause incorrect operation outdoors or when the remote sensor is directly exposed to sunlight or powerful lighting.

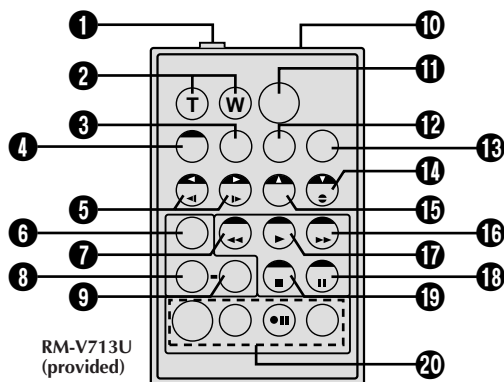

Buttons	Functions	
	With the camcorder's Power Switch set to the camera position ("CAMERA", "5S" or "DSC").	With the camcorder's Power Switch set to "PLAY/PC" or "DSC PLAY".
① PAUSE IN Connector	—	☞ pg. 85
② Zoom (T/W) Buttons	Zoom in/out (☞ pg. 24)	Zoom in/out (☞ pg. 82)
③ DISPLAY Button	—	☞ pg. 74
④ SHIFT Button	—	☞ pg. 82
⑤ SLOW Rewind/Forward Buttons Left/Right Buttons	— —	☞ pg. 82 ☞ pg. 82
⑥ FADE/WIPE Button	—	☞ pg. 85
⑦ REW Button	—	<ul style="list-style-type: none"> • Rewind/Reverse Shuttle Search on a tape (☞ pg. 52, 53) • Displays previous image in a MultiMediaCard (☞ pg. 56)
⑧ EFFECT Button	—	☞ pg. 83
⑨ EFFECT ON/OFF Button	—	☞ pg. 83
⑩ Infrared beam transmitting window	Transmits the beam signal.	
⑪ START/STOP Button	Functions same as START/STOP on the camcorder.	
⑫ AUDIO MONITOR Button	—	☞ pg. 55
⑬ MBR SET Button	—	☞ pg. 84
⑭ Down Button A.DUB Button	— —	☞ pg. 82 ☞ pg. 90
⑮ Up Button	—	☞ pg. 82
⑯ FF Button	—	<ul style="list-style-type: none"> • Forward/Forward Shuttle Search on a tape (☞ pg. 52, 53) • Displays next image in a MultiMediaCard (☞ pg. 56)
⑰ PLAY Button	—	<ul style="list-style-type: none"> • Starts Playback of a tape (☞ pg. 52) • Starts Auto Playback of a MultiMediaCard (☞ pg. 56)
⑱ PAUSE Button	—	Pauses the tape (☞ pg. 53)
⑲ STOP Button	—	<ul style="list-style-type: none"> • Stops the tape (☞ pg. 52) • Stops Auto Playback or Slide Show (☞ pg. 56, 57)
⑳ R.A.EDIT Buttons	—	☞ pg. 84 – 89

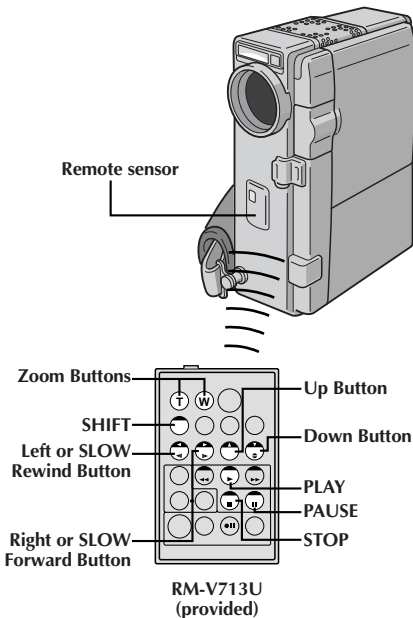
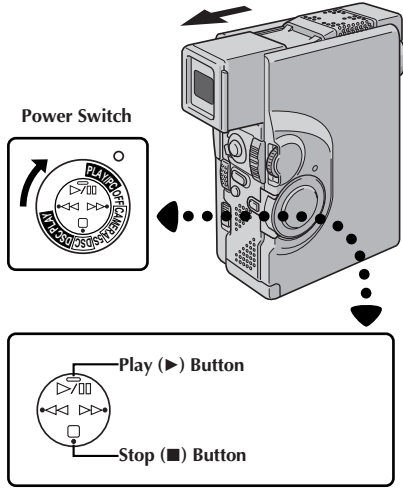

To move image, press (Right) while keeping SHIFT held down.

FEATURE: Slow-Motion Playback

PURPOSE:

To allow slow-speed search in either direction during video playback.

OPERATION:

- 1) To change from normal to Slow-Motion Playback, press **PAUSE (■)** at the point where you want to start playback in slow motion.
 - 2) Press **SLOW (◀ or ▶)**. After playing back for approx. 1 minute in Slow Rewind or approx. 2 minutes in Slow Forward, normal playback resumes.
- To stop Slow-Motion Playback in progress, press **PLAY (▶)**.

NOTES:

- During Slow-Motion Playback, due to digital image processing, the picture may take on a mosaic effect.
- After **SLOW (◀ or ▶)** is pressed, the still image may be displayed for a few seconds, then the screen may become blue back for a few seconds. This is not a malfunction.
- There may be a small margin between the slow-motion playback start point you chose and the start point at which the camcorder actually begins playback in slow motion.
- During Slow-Motion Playback, there will be disturbances in video and the picture may seem unstable, especially with steady images. This is not a malfunction.
- During Slow-Motion Playback, press **PAUSE (■)** to pause playback.

FEATURE: Frame-By-Frame Playback

PURPOSE:

To allow frame-by-frame search during video playback.

OPERATION:

- 1) To change from normal to Frame-By-Frame Playback, press **PAUSE (■)** at the point where you want to start Frame-By-Frame Playback.
- 2) Press **PAUSE (■)** repeatedly. Each time it is pressed, the frame is played back.

FEATURE: Playback Zoom

PURPOSE:

To magnify the recorded image up to 10X at any time during video playback.

OPERATION:

- 1) Press **PLAY (▶)** to find the scene of interest.
 - 2) Press the Zoom Buttons (**T/W**) on the remote control. Make sure the remote control is pointed at the camcorder's remote sensor. Pressing **T** zooms in.
 - 3) You can move the image on screen around to find a particular portion of the picture. While holding down **SHIFT**, press (Left), (Right), (Up) and (Down).
- To end zoom, press and hold **W** until magnification returns to normal. Or, press **STOP (■)** and then press **PLAY (▶)**.

NOTES:

- Zoom can also be used during slow-motion and still playback.
- During digital image processing, the quality of the image may suffer.

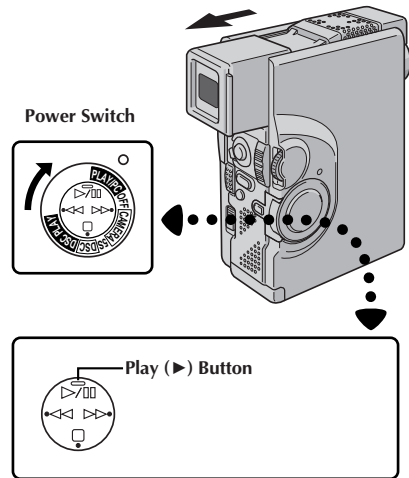

PLAYBACK EFFECT	
OFF	
1	CLASSIC FILM
2	MONOTONE
3	SEPIA
4	STROBE
5	VIDEO ECHO

PLAYBACK EFFECT Select Menu

FEATURE: Playback Special Effects

PURPOSE:

To allow you to add creative effects to the video playback image. You can use any one of the 5 effects.

OPERATION:

- 1) To start playback, press **PLAY** (▶).
- 2) Point the remote control at the camcorder's remote sensor and press **EFFECT**. The **PLAYBACK EFFECT Select Menu** appears.
- 3) Move the highlight bar to the desired effect by pressing **EFFECT**. The selected function is activated and after 2 seconds the menu disappears.
 - To deactivate the selected effect, press **EFFECT ON/OFF** on the remote control. Pressing it again re-activates the selected effect.
 - To change the selected effect, repeat from step 2 of the above "OPERATION".

NOTES:

- When some Playback Special Effects are used, the Multi-Analyser 4 and Multi-Analyser 9 Snapshot modes (pg. 31) are not available.
- The effects that can be used during playback are Classic Film, Monotone, Sepia, Strobe and Video Echo. The effects work the same in playback as they did in recording. Refer to page 45 for more information.

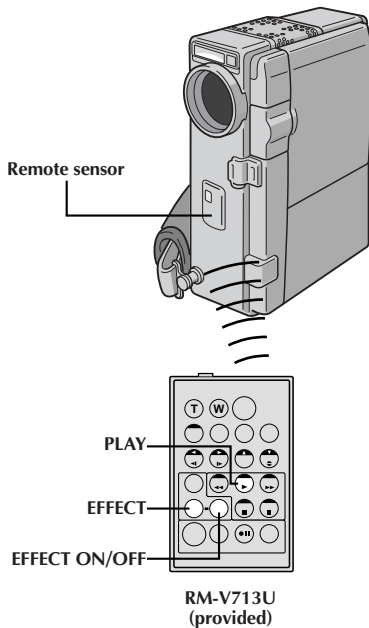

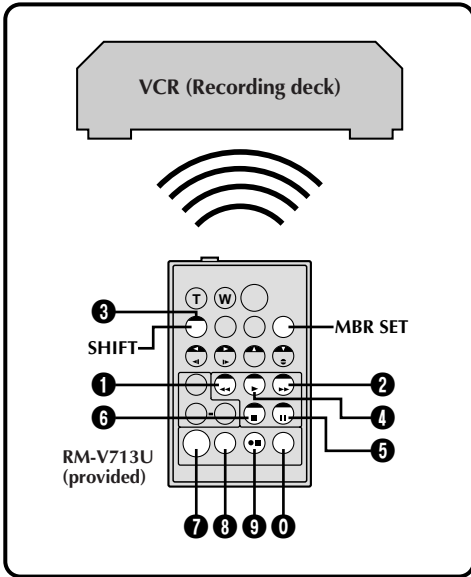

VCR CODE LIST

VCR BRAND NAME	BUTTONS (A) (B)	VCR BRAND NAME	BUTTONS (A) (B)
AKAI	6 2 6 4 7 7	PHILIPS	1 9 9 5 1 1 9 4 9 1 9 6 1 2 3 3 7 2
BLAUPUNKT	1 3	SANYO	3 6 3 5
FERGUSON	9 7 9 8 3 2	SELECO, REX	9 1 9 6
GRUNDIG	1 4 3 4	SHARP	1 5 1 0
HITACHI	6 6 6 3	SONY	6 5 6 0 3 9 3 1
JVC A B C	9 1 9 6 9 3	THOMSON, TELEFUNKEN, SABA, NORDMENDE	9 1 9 6 9 7 3 2
MITSUBISHI	6 7 6 8	TOSHIBA	6 9 6 1
NEC	3 7 3 8		
PANASONIC	1 3 1 7 1 1 9 4 1 8		

Random Assemble Editing [R.A.Edit]

Create edited videos easily using your camcorder as the source player. You can select up to 8 "cuts" for automatic editing, in any order you like. R.A.Edit is more easily performed when the RM-V713U MBR (Multi-Brand Remote, see pg. 81) is set to operate with your brand of VCR (see VCR CODE LIST), but can also be performed by operating the VCR manually.

Before operation, make sure the lithium battery is installed in the remote control RM-V713U (see pg. 80).

SET REMOTE/VCR CODE

1 SET REMOTE TO OPERATE VCR

Turn off the power to the VCR and point the remote towards the VCR's infrared sensor. Then, referring to the VCR CODE LIST on the left, press and hold **MBR SET**, and press button (A) and then (B).

- The code is automatically set once you release **MBR SET**, and the VCR's power comes on.

2 OPERATE VCR

Make sure the VCR's power is on. Then, while holding **SHIFT**, press the button on the remote for the desired function. The functions the remote can control are PLAY, STOP, PAUSE, FF, REW and VCR REC STBY (you do not need to press **SHIFT** for this one).

You are now ready to try Random Assemble Editing.

IMPORTANT

Although the MBR is compatible with JVC VCRs and those of many other makers, it may not work with yours or may offer limited functions.

NOTES:

- If the VCR's power does not come on in step 1, try another code from the VCR CODE LIST.
- Some brands of VCR do not come on automatically. In this case, turn the power on manually and try step 2.
- If the remote control is not able to control the VCR, use the controls on the VCR.
- When the remote control's battery runs out, the VCR brand you have set will be erased. In that case, replace the old battery with a new one to reset the VCR brand.

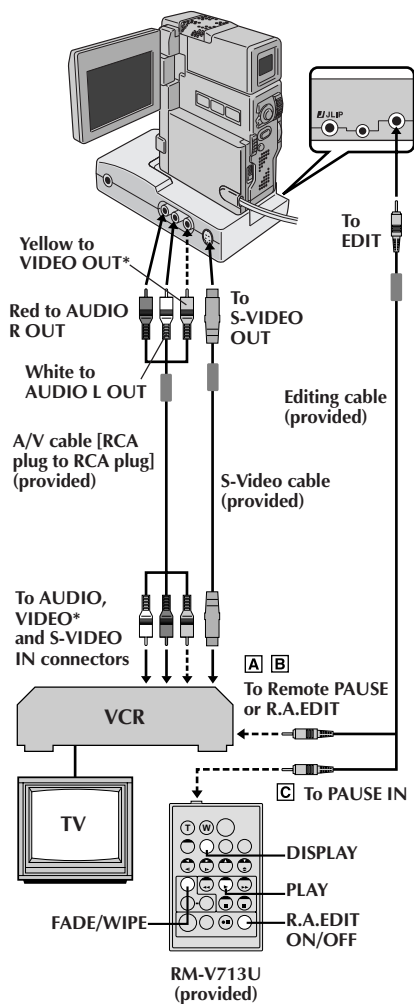

MAKE CONNECTIONS

Also refer to pg. 70, 71 and 73.

1 CONNECT TO . . .

[A] JVC VCR EQUIPPED WITH REMOTE PAUSE TERMINAL

Connect the editing cable to the Remote PAUSE terminal.

[B] JVC VCR NOT EQUIPPED WITH REMOTE PAUSE TERMINAL BUT EQUIPPED WITH R.A.EDIT CONNECTOR

Connect the editing cable to the R.A.EDIT connector.

[C] VCR OTHER THAN TYPE [A] OR [B]

Connect the editing cable to the RM-V713U's PAUSE IN connector.

2 PREPARE CAMCORDER

Insert a recorded tape and set the Power Switch to "PLAY/PC" while pressing down the Lock Button.

3 PREPARE VCR

Turn the power on, insert a recordable tape and engage the AUX mode (refer to VCR's instructions).

SELECT SCENES

4 START SOURCE PLAYBACK

Press **PLAY** (▶) and then press **R.A.EDIT ON/OFF** on the remote control. Make sure to point the remote control at the camcorder's remote sensor.

- The Random Assemble Editing Menu appears.

5 EXECUTE FADE/WIPE IN (IF NECESSARY)

Press **FADE/WIPE** on the remote control.

- Cycle through the effects by pressing repeatedly, and stop when the one you want is displayed.
- You cannot use a Picture Wipe/Dissolve at the beginning of Programme 1.

* Connect when the S-Video cable is not used.

NOTES:

- You can use the AV OUT connector on the camcorder for connection.
- Before Random Assemble Editing, make sure the indications do not appear on the TV monitor. If they appear during Random Assemble Editing, they will be recorded onto the new tape. To clear the Playback Sound Mode Display, press **DISPLAY** on the remote control. Select "DISPLAY" and "TIME CODE" from the Playback Menu (☞ pg. 54) to show or hide the Date/Time and the Time Code on the recording. To show or hide all indications except for the Random Assemble Editing Menu, set "INDICATION" to "OFF" in the Playback Menu (☞ pg. 54) and press **DISPLAY** on the remote control. When Random Assemble Editing starts, its indications disappear and are not recorded on the new tape.
- When editing on a VCR equipped with DV input connector, the DV cable can be connected instead of the S-Video cable and Audio/Video cable.

CONTINUED ON NEXT PAGE

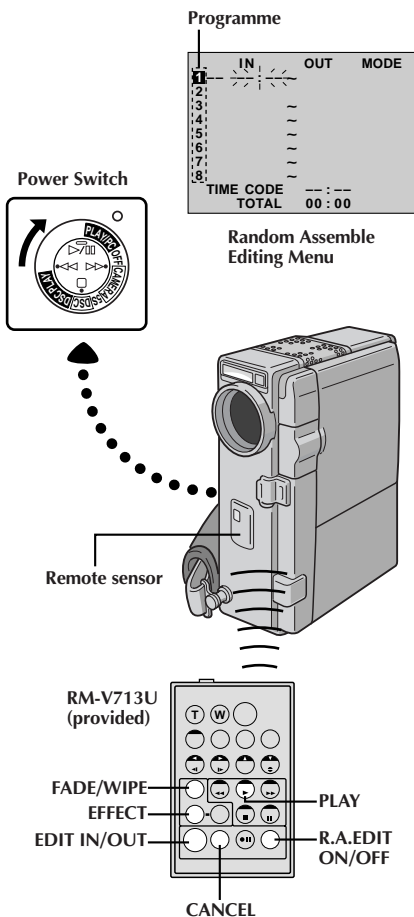

SELECT SCENES (cont.)

6 SET EDIT-IN POINT

At the beginning of the scene, press **EDIT IN/OUT** on the remote control. The Edit-In position appears on the Random Assemble Editing Menu.

7 SET EDIT-OUT POINT

At the end of the scene, press **EDIT IN/OUT**. The Edit-Out position appears on the Random Assemble Editing Menu.

8 USE FADE/WIPE ON SCENE TRANSITION (IF NECESSARY)

Press **FADE/WIPE**.

- Cycle through the effects by pressing repeatedly, and stop when the one you want is displayed.
- If you select a Fade/Wipe effect for an Edit-Out point, the effect is automatically applied to the following Edit-In point.
- You cannot use a Picture Wipe/Dissolve at the end of the last scene.
- When you use Fade/Wipe effects, that time is included in the total time (this does not apply to Picture Wipe/Dissolve).

9 USE PLAYBACK SPECIAL EFFECTS (IF NECESSARY, see pg. 83)

Press **EFFECT**.

10 REGISTER ADDITIONAL SCENES

Repeat steps 6 through 9.

- To change previously registered points, press **CANCEL** on the remote control. The registered points disappear, one at a time, from the most recently registered point.
- If you are not using Fade/Wipe or Programme AE with special effects, repeat steps 6 and 7 only.

NOTES:

- When the source tape has more than 2 identical time codes (see pg. 25), the camcorder may not find the Edit-In point you chose and a malfunction may occur.
- When choosing a scene, set Edit-In and Edit-Out points so that there is a relatively large difference between them.
- If the search time for an in-point exceeds 5 minutes, the recording deck's Record-Standby mode will be cancelled and editing will not take place.
- If there are blank portions before or after the Edit-In and Edit-Out points, a blue-backed screen may be included in the edited version.
- Since time codes register time only as accurately as seconds, the time code total time may not match the total programme time exactly.
- Turning off the camcorder's power erases all registered Edit-In and Edit-Out points.
- If you select Sepia or Monotone mode from Programme AE with special effects, you cannot use the Dissolve or Black & White Fader. In this case the Dissolve or Black & White indicator begins blinking. Once the next Edit-In point is registered, the effect is turned off. To combine these effects, use Sepia or Monotone during recording, then use Dissolve or Black & White Fader during Random Assemble Editing.
- It is not possible to use Fade/Wipe effects and Programme AE with special effects during Random Assemble Editing using a DV cable.

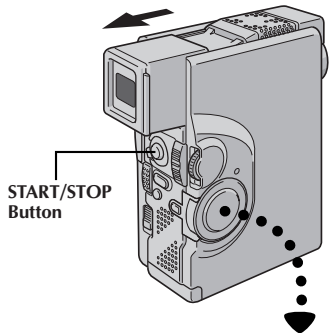
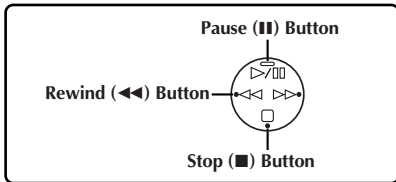
START/STOP
Button

	IN	OUT	MODE
1	00 : 25	02 : 05	P
2	07 : 18	08 : 31	B/W
3	03 : 33	05 : 53	B/W
4	09 : 30	13 : 15	B/W
5	15 : 55	16 : 20	B/W
6			
7			
8			
	TIME CODE	16 : 30	
	TOTAL	9 : 39	

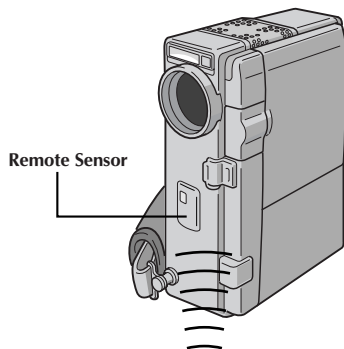
Random Assemble
Editing Menu

Remote Sensor

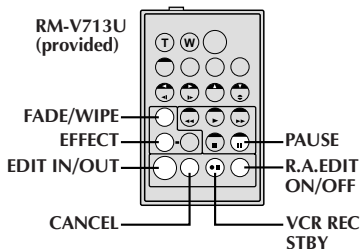

AUTOMATIC EDITING TO VCR

11 PREPARE SOURCE TAPE

Rewind the tape in the camcorder to the beginning of the scene you want to edit and press **PAUSE (II)**.

12 ENGAGE VCR'S RECORD-PAUSE MODE

Point the remote control towards the VCR's remote sensor and press **VCR REC STBY (● II)**, or manually engage the VCR's Record-Pause mode.

13 START EDITING

Press **START/STOP** on the camcorder. Editing proceeds as programmed, right through to the end of the last registered scene.

- Pressing **START/STOP** on the remote control does not start editing.
- When dubbing is complete, the camcorder enters the Pause mode, and the recording deck enters its Record-Standby mode.
- If you do not register an Edit-Out point, the tape will be dubbed all the way to the end automatically.

14 STOP EDITING

Engage the Stop modes for the camcorder and the VCR.

To make the R.A.Edit counter display disappear, press **R.A.EDIT ON/OFF** on the remote control.

NOTES:

- Pressing **R.A.EDIT ON/OFF** on the remote control clears all settings registered during Random Assemble Editing.
- When the editing cable is connected to the Pause terminal during dubbing, make sure the remote control is pointed at the VCR's sensor, and that the path between the two is unobstructed.
- Random Assemble Editing may not function properly when using a tape including several duplicated Time Codes (see pg. 25).

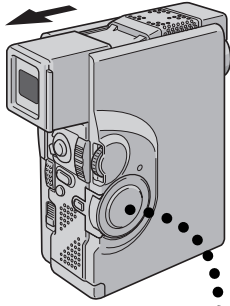

Programme 1

	IN	OUT	MODE
1	---	---	---
2	---	---	---
3	---	---	---
4	---	---	---
5	---	---	---
6	---	---	---
7	---	---	---
8	---	---	---
TIME CODE	---	---	---
TOTAL	00:00	---	---

Random Assemble Editing Menu

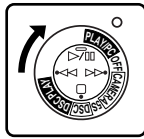

Power Switch



TV

VCR
(Recording deck)

Remote sensor

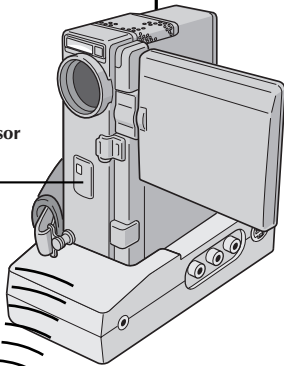

RM-V713U
(provided)

R.A.EDIT
ON/OFF

For More Accurate Editing

Some VCRs make the transition from Record-Standby to Record mode faster than others. Even if you begin editing for the camcorder and the VCR at exactly the same time, you may lose scenes you wanted, or find that you have recorded scenes you did not want. For a cleanly edited tape, confirm and adjust the timing of the camcorder against your VCR.

DIAGNOSING VCR'S AGAINST CAMCORDER TIMING

1

PREPARE FOR R.A.EDIT

Play back the tape in the camcorder, then point the remote control at the camcorder's remote sensor and press **R.A.EDIT ON/OFF**.

- "Random Assemble Editing Menu" appears.

2

CHOOSE A SCENE

Perform Random Assemble Editing on Programme 1 only. In order to check VCR and camcorder timing, select the beginning of a scene transition as your Edit-In point.

3

PLAY BACK DUBBED SCENE

- If any images from the scene prior to the transition you chose for your Edit-In point were recorded, that means your VCR moves quickly from Record-Pause to Record mode.
- If the scene you tried to dub starts in progress, the VCR is slow to start recording.

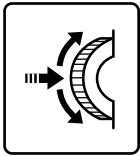
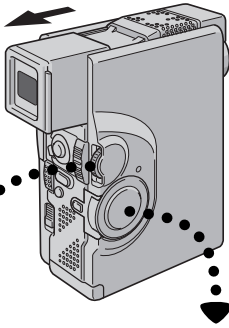

MENU/SET Dial

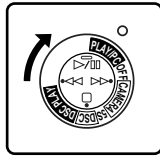

Power Switch

Display

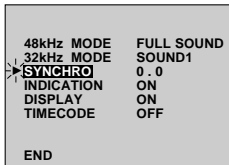

Playback Menu

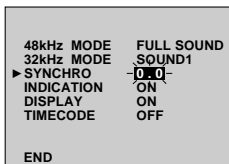

ADJUSTMENT OF VCR'S AGAINST CAMCORDER TIMING

4 ACCESS PLAYBACK MENU

Point the remote control at the camcorder's remote sensor and press **R.A.EDIT ON/OFF** to make the Random Assemble Editing menu disappear, then press **MENU/SET**. The Playback Menu appears.

5 SELECT FUNCTION

Move the highlight bar to "SYNCHRO" by rotating **MENU/SET**, then press it. The value for "SYNCHRO" is highlighted.

6 INPUT CORRECTION DATA

Based on the diagnostics performed (☞ pg. 88), you can now increase the VCR's speed by rotating **MENU/SET** upward. You can also slow down the VCR's speed by rotating **MENU/SET** downward. The adjustment range is from -1.3 to +1.3 seconds, in 0.1-second increments.

7 CLOSE MENU

Press **MENU/SET** twice.

- Now perform Random Assemble Editing beginning with step 4 on page 85.

NOTES:

- Before performing actual Random Assemble Editing, do a few Random Assemble Editing trial runs to check whether the value you have input is appropriate or not, and make adjustments accordingly.
- Depending on the recorder, there may be situations where the timing difference cannot be fully corrected.

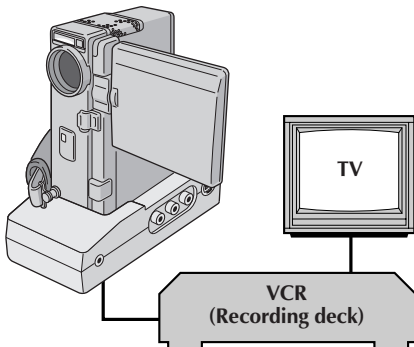

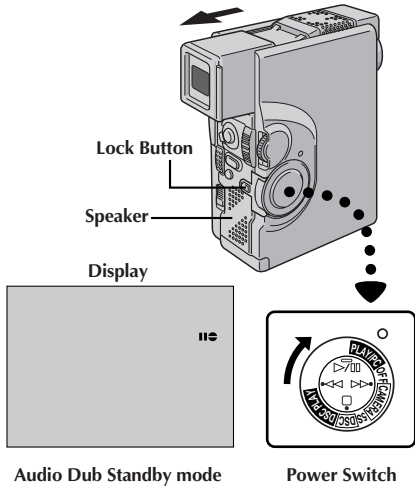

Audio Dubbing

The audio track can be customized only when recorded on the 32 kHz mode (☞ pg. 39).

NOTES:

- Audio Dubbing is not possible on a tape recorded at 48 kHz, on a tape recorded in the LP mode or on a blank portion of a tape.
- To perform Audio Dubbing while watching in the television, make connections (☞ pg. 70).

- FIND EDIT-IN POINT**
Play back the tape to locate the point where editing will start, then press PAUSE (II).
- ENGAGE AUDIO DUB STANDBY**
While holding A.DUB (⊕) on the remote control, press PAUSE (II). "II⊕" appears.
- BEGIN DUBBING**
Press PLAY (▶), then begin "narrating".
• Speak into the microphone.
- PAUSE DURING DUBBING**
Press PAUSE (II).
- STOP DUBBING**
Press STOP (■).

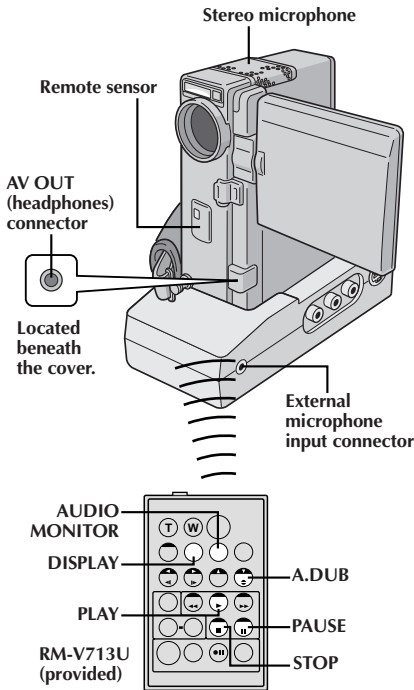

NOTES:

- Audio dubbing is also possible using an optional microphone.
- While an optional microphone is connected, the built-in microphone is disabled.
- When editing onto a tape that was recorded at 32 kHz, the old and new soundtracks are recorded separately.
- To select the desired sound for playback, press **AUDIO MONITOR** on the remote control.
- If you dub onto a blank space on the tape, the sound may be disrupted. Make sure you only edit recorded areas.
- If feedback or howling occurs during TV Playback, move the camcorder's microphone away from the TV, or turn down the TV's volume.
- Sound is not heard from the speaker during Audio Dubbing. To hear sound, connect optional headphones to the AV OUT (headphones) connector.
- If you change from 32 kHz to 48 kHz in mid-recording and then use the tape for Audio Dubbing, it is not effective from the point where 48 kHz recording began.
- During Audio Dubbing, when the tape moves to scenes recorded in the LP mode, scenes recorded at 48 kHz or a blank portion, Audio Dubbing stops and "ERROR! REFER MANUAL" appears.

Recording sound	Display	Output sound
32 kHz	FULL SOUND	Original and new tracks are combined and output in stereo.
	SOUND 2	New track is output on both "L" and "R" channels in stereo.
	SOUND 1	Original track is output on both "L" and "R" channels in stereo.

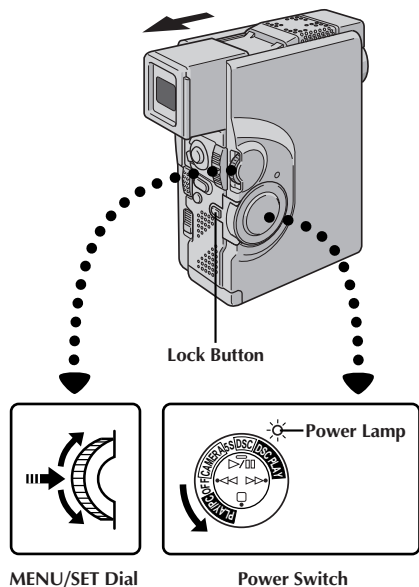

Display

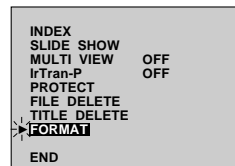

Playback Menu

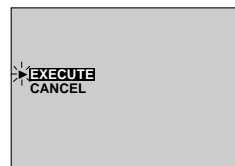

Format Confirmation Screen

Initializing A MultiMediaCard

If the MultiMediaCard's memory is corrupt, "PLEASE INITIALIZE" will appear. In this case, you will have to initialise the MultiMediaCard.

- 1 SELECT OPERATION MODE**
Set the Power Switch to "DSC PLAY", while pressing down the Lock Button. Open the LCD monitor fully or pull out the viewfinder fully.
- 2 ACCESS PLAYBACK MENU**
Press MENU/SET. The Playback Menu appears.
- 3 SELECT FUNCTION**
Rotate MENU/SET to move the highlight bar to "FORMAT" and press it. The Format Confirmation Screen appears.
- 4 INITIALIZE MULTIMEDIACARD**
Rotate MENU/SET to move the highlight bar to "EXECUTE" and press it. The MultiMediaCard is initialised.
 - If you wish to cancel initialization, rotate MENU/SET to select "CANCEL" and press it.

NOTES:

- After initializing, all images stored in the MultiMediaCard, including those which have been protected, are cleared.
- Initialization is possible only when "PLEASE INITIALIZE" appears.





CAUTION:

Do not perform any other operation (such as turning off the camcorder) during initialization. Also, be sure to use the provided AC Power Adapter/Charger, as the MultiMediaCard may be corrupted if the battery becomes exhausted during initialization.

If, after following the steps in the chart below, the problem still exists, please consult your nearest JVC dealer.

The camcorder is a microcomputer-controlled device. External noise and interference (from a TV, a radio, etc.) might prevent it from functioning properly. In such cases, first disconnect its power supply unit (battery pack, AC Power Adapter/Battery Charger, etc.) and wait a few minutes; and then re-connect it and proceed as usual from the beginning.

SYMPTOM	POSSIBLE CAUSES	CORRECTIVE ACTION
1. No power is supplied.	1. <ul style="list-style-type: none"> • The power is not connected properly. • The battery is dead. • The LCD monitor is not open fully or the viewfinder is not pulled out when recording. 	1. <ul style="list-style-type: none"> • Connect the AC Power Adapter/Charger securely (☞ pg. 9). • Replace the dead battery with a fully charged one (☞ pg. 8, 9). • Open the LCD monitor fully or pull out the viewfinder. The LCD monitor turns on/off when it is opened/closed at approx. 90° while the Power Switch is set to any position except "OFF" if the viewfinder is not fully pulled out.
2. "SET DATE/TIME!" appears.	2. <ul style="list-style-type: none"> • The built-in clock's rechargeable lithium battery is discharged. • The previously set date/time is erased. 	2. <ul style="list-style-type: none"> • Connect the camcorder to an AC outlet using the AC Power Adapter/Charger for over 24 hours to charge the clock's lithium battery (☞ pg. 11).
3. Recording cannot be performed.	3. <ul style="list-style-type: none"> • The tape's erase protection switch is set to "SAVE". • The Power Switch is set to "PLAY/PC". • "TAPE END" appears. • The cassette's cover is open. 	3. <ul style="list-style-type: none"> • Set the tape's erase protection switch to "REC" (☞ pg. 12). • Set the Power Switch to any position except "PLAY/PC" or "OFF" (☞ pg. 17). • Replace with new cassette (☞ pg. 12). • Close the cassette's cover.
4. There is no picture.	4. <ul style="list-style-type: none"> • The camcorder is not getting power, or some other malfunction exists. 	4. <ul style="list-style-type: none"> • Turn the camcorder's power off and on again (☞ pg. 18).
5. Some functions are not available using MENU/SET.	5. <ul style="list-style-type: none"> • The Operation Switch is set to "A". 	5. <ul style="list-style-type: none"> • Set the Operation Switch to "M" (☞ pg. 17).
6. The focus does not adjust automatically.	6. <ul style="list-style-type: none"> • Focus is set to "MANUAL". • The recording was done in a dark place, or the contrast was low. • The lens is dirty or covered with condensation. 	6. <ul style="list-style-type: none"> • Set Focus to "AUTO" (☞ pg. 47). • Clean the lens and check the focus again (☞ pg. 98).
7. The cassette will not load properly.	7. <ul style="list-style-type: none"> • The cassette is in the wrong position. • The battery's charge is low. 	7. <ul style="list-style-type: none"> • Set it in the right position (☞ pg. 12). • Install a fully charged battery (☞ pg. 8, 9).
8. The MultiMediaCard will not load properly.	8. <ul style="list-style-type: none"> • The MultiMediaCard is in the wrong position. 	8. <ul style="list-style-type: none"> • Set it in the right position (☞ pg. 14).
9. In the 5-Second mode, recording ends before 5 seconds have elapsed.	9. <ul style="list-style-type: none"> • The 5-Second mode in the System Menu is set to "ANIM.". 	9. <ul style="list-style-type: none"> • Select "5S" or "5SD" in the System Menu (☞ pg. 34 – 39).

SYMPTOM	POSSIBLE CAUSES	CORRECTIVE ACTION
10. Snapshot mode cannot be used.	10. • The Squeeze mode is selected.	10. • Disengage the Squeeze mode (☞ pg. 37).
11. Although Snapshot is attempted, flash does not take place.	11. • The subject is too bright with the flash set to "AUTO" or "AUTO  ". • If  blinks, the flash is being charged. • Multi-Analyser 4 or Multi-Analyser 9 is selected. • The camcorder is in the Record mode.	11. • Set "FLASH" to "ON" in the Mode Menu (☞ pg. 32). • It can take up to 10 seconds to charge the flash. • Disengage Multi-Analyser 4 or Multi-Analyser 9 (☞ pg. 23, 31). • Set the camcorder in the Record-Standby mode (☞ pg. 32).
12. Although Snapshot is taken with the flash, Red-Eye Reduction does not take place.	12. • The subject does not look straight toward the flash. • The subject does not look at the first flash, which is an important part of Red-Eye Reduction. • The camcorder is too far from the subject. • "FLASH" is not set to "AUTO  " in the Mode Menu.	12. • The subject should look straight toward the flash, especially the first flash. If the subject does not see the first flash, it will be difficult for Red-Eye Reduction to take place (☞ pg. 32). • The flash is effective for subjects at a distance of approx. 0.7 m to 2 m from the camcorder (☞ pg. 32). • Set "FLASH" to "AUTO  " in the Mode Menu to display the Red-Eye Reduction indicator (☞ pg. 32).
13. The image taken using Snapshot is too dark.	13. • "FLASH" is set to "OFF" in the Mode Menu. • The flash emission window is covered by fingers, etc.. • The flash brightness is set to produce a darker image (adjustment value: -3). • The camcorder is too far from the subject.	13. • Set "FLASH" to any position except "OFF" in the Mode Menu (☞ pg. 32). • Do not cover the flash emission window. • Adjust the flash brightness to a larger value (☞ pg. 33). • The flash is effective for subjects at a distance of approx. 0.7 m to 2 m (☞ pg. 32).
14. The image taken using Snapshot is too bright.	14. • "FLASH" is set to "ON" in the Mode Menu.	14. • Set "FLASH" to any parameter other than "ON" in the Mode Menu (☞ pg. 32).
15. The colour of Snapshot looks strange.	15. • The light source or the subject does not include white. Or there are various different light sources behind the subject.	15. • Set "FLASH" to "ON" in the Mode Menu. Or find a white subject and compose your shot so that it also appears in the frame (☞ pg. 32).
16. Digital Zoom does not work.	16. • 10X optical zoom is selected. • The Video Echo mode is activated. • Picture Wipe or Dissolve are being used in a scene transition. • 5-Second recording was done with the Power Switch set to "5S", and with "5SD" selected in the System Menu.	16. • Turn off the Video Echo mode (☞ pg. 45). • Wait until the Picture Wipe or Dissolve effects are completed (☞ pg. 41 - 43). • Change the setting of either the System Menu or the Power Switch (☞ pg. 28).

SYMPTOM	POSSIBLE CAUSES	CORRECTIVE ACTION
17. Programme AE with special effects and Fade/Wipe Effects do not work.	17. • The Operation Switch is set to "A" and/or the Power Switch is set to "5S".	17. • Set the Operation Switch to "M" and/or set the Power Switch to "CAMERA" or "DSC".
18. The Black & White Fader does not work.	18. • The Sepia or Monotone mode is activated.	18. • Turn off Sepia and Monotone (☞ pg. 44).
19. The Dissolve function does not work.	19. • The Sepia, Monotone or Slow Shutter mode of Programme AE with special effects is activated. • The Squeeze mode is selected. • The previously selected mode of Programme AE with special effects was changed after the last selected scene for editing was registered.	19. • Turn off Sepia, Monotone or Slow Shutter before adding Dissolve to a scene transition (☞ pg. 44). • Make sure that the Squeeze mode in the Mode Menu is set to "OFF" (☞ pg. 37). • Make sure you have selected the mode of Programme AE with special effects you want before starting editing (☞ pg. 44).
20. The Picture Wipe and Dissolve functions do not work.	20. • The last selected editing scene is ending. • At the end of the last selected scene for editing, the Power Switch was set to "OFF". • The power is off.	20. • Select Picture Wipe or Dissolve before beginning recording. The effects are then automatically activated (☞ pg. 42). • Do not turn off the camcorder's power after setting Edit-In and Edit-Out points, as they will all be erased (☞ pg. 42). • The camcorder automatically shuts off after 5 minutes have elapsed in the Record-Standby mode. Make sure you continue operations within 5 minutes after engaging Record-Standby mode (☞ pg. 42).
21. The picture wipe function doesn't work.	21. • The Slow Shutter mode is activated. • The Squeeze or Cinema mode is selected in the Mode Menu.	21. • Make sure the Squeeze mode, Cinema mode, or Slow Shutter mode is not activated when preparing to use the Picture Wipe function (☞ pg. 37, 45).
22. Scene transition does not go as expected.	22. • When using "Picture Wipe/Dissolve" (☞ pg. 42) or "Dissolves during 5 second recording mode" (☞ pg. 28), there is a delay of a fraction of a second between the previous record stop-point and the Dissolve start-point. This is normal, but this slight delay becomes especially noticeable when shooting fast-moving subject or during rapid panning.	22.

SYMPTOM	POSSIBLE CAUSES	CORRECTIVE ACTION
23. The Video Echo mode does not work.	23. • The Picture Wipe or Dissolve functions are in use. • The Squeeze mode is selected in the Mode Menu. • A Fade-In or Fade-Out is in progress. • Dissolve during 5-second mode recording is in use.	23. • Make sure the Squeeze mode is set to "OFF" (☞ pg. 34 – 39). • Do not try to use the Video Echo mode during a Fade-In or Fade-Out or when Dissolve is activated during 5-second mode recording (☞ pg. 44, 45).
24. Even when Slow Shutter is not selected, the image looks like it is activated.	24. • When shooting in the dark, the unit becomes highly sensitive to light and the image takes on an effect similar to Slow Shutter.	24. • If you want the lighting to look more natural, set GAIN UP to "AGC" or "OFF" in the Mode Menu (☞ pg. 34 – 39).
25. There is no strobe when the Classic Film or Strobe mode is activated.	25. • The Picture Wipe or Dissolve function is in use. • Dissolve during 5-second mode recording is in use.	25. • Do not try to use the Classic Film or Strobe mode during a scene transition (☞ pg. 44, 45).
26. White Balance cannot be activated.	26. • The Sepia or Monotone mode is activated.	26. • Turn off Sepia or Monotone before setting White Balance (☞ pg. 44, 45).
27. When shooting a subject illuminated by bright light, vertical lines appear.	27. • This is a result of exceedingly high contrast, and is not a malfunction.	27. _____
28. When the screen is under direct sunlight during shooting, the screen becomes red or black for an instant.	28. • This is not a malfunction.	28. _____
29. During recording, the date/time does not appear.	29. • "DISPLAY" is set to "OFF" in the Date/Time Menu. • Interface Shooting is performed.	29. • Set "DISPLAY" to "ON" in the Date/Time Menu (☞ pg. 26). • During Interface Shooting, the date/time does not appear (☞ pg. 21). • Set "INDICATION" to "ON" in the Date/Time Menu (☞ pg. 27).
30. Images stored in the MultiMediaCard cannot be deleted.	30. • Images stored in the MultiMediaCard are protected.	30. • Remove protection from the images stored in the MultiMediaCard and delete them (☞ pg. 62, 64).
31. The indicators and messages do not appear.	31. • "ON SCREEN" is set to "OFF" in the Date/Time Menu. • You have made the indicators disappear.	31. • Set "ON SCREEN" to "ON" in the Date/Time Menu (☞ pg. 26). • Set "INDICATION" to "ON" in the Date/Time Menu (☞ pg. 27).
32. Images on the LCD monitor appear dark or whitish.	32. • In places subject to low temperature, images become dark due to the characteristics of the LCD monitor. When this happens, the displayed colours differ from those that are actually recorded. This is not a defect of the camcorder. • When the LCD monitor's fluorescent light reaches the end of its service life, images on the LCD monitor become dark. Consult your nearest JVC dealer.	32. • Adjust the brightness and angle of the LCD monitor (☞ pg. 21).

SYMPTOM	POSSIBLE CAUSES	CORRECTIVE ACTION
33. The rear of the LCD monitor is hot.	33. • The light used to illuminate the LCD monitor causes it to become hot.	33. • Close the LCD monitor to turn it off or set the Power Switch to "OFF", and let the unit cool down.
34. The indicators and the image colour on the LCD monitor are not clear.	34. • This may occur when the surface or the edge of the LCD monitor is pressed.	34. _____
35. The LCD monitor or viewfinder indications blink.	35. • Certain Fade/Wipe effects, certain modes of Programme AE with special effects, "DIS" and other functions that cannot be used together are selected at the same time.	35. • Re-read the sections covering Fade/Wipe effects, Programme AE with special effects and "DIS" (☞ pg. 37, 41 – 45).
36. Coloured bright spots appear all over the LCD monitor or the viewfinder.	36. • The LCD monitor and the viewfinder are made with high-precision technology. However, black spots or bright spots of light (red, green or blue) may appear constantly on the LCD monitor or the viewfinder. These spots are not recorded on the tape. This is not due to any defect of the unit. (Effective dots: more than 99.99 %)	36. _____
37. During recording, sound cannot be heard.	37. • The optional headphones are not connected to the headphones connector. • The sound volume of the headphones connector was not adjusted appropriately. The sound volume at this point is the same as the level it was adjusted to during playback.	37. • Connect the optional headphones to the headphones connector (☞ pg. 100). • Adjust the sound volume during playback (☞ pg. 52).
38. Play, Rewind and Fast-Forward functions do not work.	38. • The Power Switch is not set to "PLAY/PC".	38. • Set the Power Switch to "PLAY/PC" (☞ pg. 52).
39. The tape is moving, but there is no picture.	39. • Your TV has AV input terminals, but is not set to its VIDEO mode. • The cassette's cover is open.	39. • Set the TV to the mode or channel appropriate for video playback (☞ pg. 70, 71). • Close the cassette's cover (☞ pg. 12).
40. The LCD monitor indications are distorted.	40. • During playback of the unrecorded portion, High-speed Search and still playback, LCD monitor indications appear distorted. This is not a defect.	40. _____

SYMPTOM	POSSIBLE CAUSES	CORRECTIVE ACTION
41. Images on the LCD monitor are jittery.	41. • The speaker volume is too great.	41. • Turn the speaker volume down (☞ pg. 52).
42. The LCD monitor, the viewfinder and the lens have become dirty (ex. finger-prints).	42. _____	42. • Wipe them gently with soft cloth. Wiping strongly can cause damage.
43. An unusual mark appears.	43. _____	43. • Check the section of the manual that explains LCD monitor/viewfinder indications (☞ pg. 102 – 105).
44. An error indication (E01 — E06) appears.	44. • A malfunction of some kind has occurred. In this case the camcorder's functions become unusable.	44. • Remove the power supply (battery pack, etc.) and wait a few minutes for the indication to clear. When it does, you can resume using the camcorder. If the indication remains even though you repeat the above two or three times, please consult your nearest JVC dealer.
45. The charger indicator on the AC Power Adapter/Charger does not light.	45. • The temperature of the battery is extremely high/low. • Charging is difficult in places subject to extremely high/low temperatures.	45. • To protect the battery, it is recommended to charge it in places with a temperature of 10°C to 35°C (☞ pg. 107).
46. The recording mode indicator "LP" blinks.	46. • This occurs when recording in the LP mode is not available. After the indicator blinks, the recording mode switches to "SP" and recording goes on.	46. _____
47. Picture does not appear on the LCD monitor.	47. • The viewfinder is pulled out. • The LCD monitor's brightness setting is too dark.	47. • Push the viewfinder back in. • Adjust the brightness of the LCD monitor (☞ pg. 21). • If the monitor is tilted upward 180 degrees, open the monitor fully (☞ pg. 20).
48. When the image is printed from the printer, a black bar appears at the bottom of the screen.	48. • This is not a malfunction.	48. • By recording with "DIS" activated (☞ pg. 37) this can be avoided.
49. When the camcorder is connected via the DV connector, the camcorder does not operate.	49. • The DV cable was plugged/unplugged with power turned on.	49. • Turn the camcorder's power off and on again, then operate it.

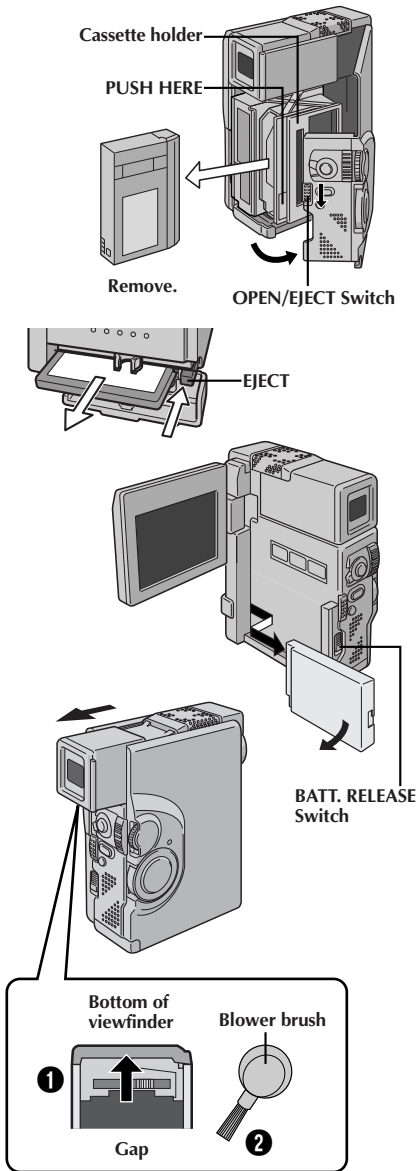
**NOTES:**

- Avoid using strong cleaning agents such as benzine or alcohol.
- Cleaning should be done only after the battery pack has been removed or other power units have been disconnected.
- Mold may form if the lens is left dirty.
- When using a cleaner or chemically treated cloth refer to the cautions of each product.

After Use

- 1 Turn off the camcorder.
- 2 Slide down **OPEN/EJECT** in the direction of the arrow, then swing the cover open until it locks. The cassette holder opens automatically. Remove the cassette.
- 3 Press "PUSH HERE" to close the cassette cover.
- 4 Open the card cover, then press **EJECT**. The MultiMediaCard is disengaged from the camcorder. Remove the MultiMediaCard.
- 5 Close the card cover.
- 6 Slide down **BATT. RELEASE** and remove the battery pack.

Cleaning The Camcorder

- 1 **CLEAN EXTERIOR**
Wipe gently with a soft cloth.
 - Put cloth in diluted mild soap and wring it well to wipe off heavy dirt. Then wipe again with a dry cloth.
- 2 **CLEAN LCD MONITOR**
Wipe gently with the provided cleaning cloth or a commercially available soft cloth. Be careful not to damage the monitor. Close the LCD monitor.
- 3 **CLEAN LENS**
Blow it with a blower brush, then wipe gently with lens cleaning paper.
- 4 **PULL OUT VIEWFINDER FULLY**
- 5 **CLEAN VIEWFINDER**
Slide the cover in the direction of the arrow ①. Insert a lens blower or a soft cloth into the gap at the bottom of the viewfinder and clean the interior of the viewfinder with it ②.
- 6 **PUSH VIEWFINDER BACK IN**
Close the cover until it locks in place. Push the viewfinder back in.

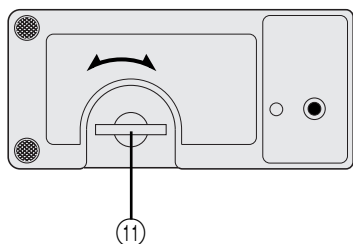
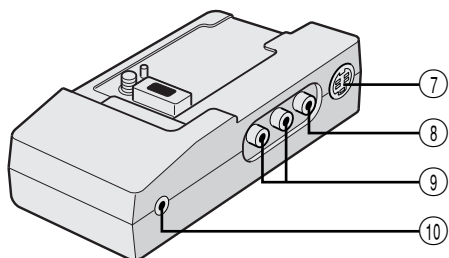
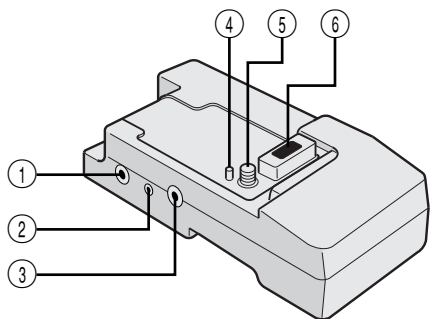

- ① JLIP (Joint Level Interface Protocol) Connector
Connect to a JLIP-compatible camcorder or VCR to control it from the computer using the provided Software.

NOTE:

Make sure that the camcorder is turned on while connecting the camcorder to a PC using the Docking Station's JLIP connector. If the camcorder is turned off (because the Power Switch is set to "OFF" or due to Auto Shut Off* etc.) while the JLIP programmeme software is used, it will be impossible to control the connected devices from the computer. In such a case, first try turning the camcorder on again, or unplug the JLIP connection cable from the Docking Station's JLIP connector. Then, initialise or run the software again.







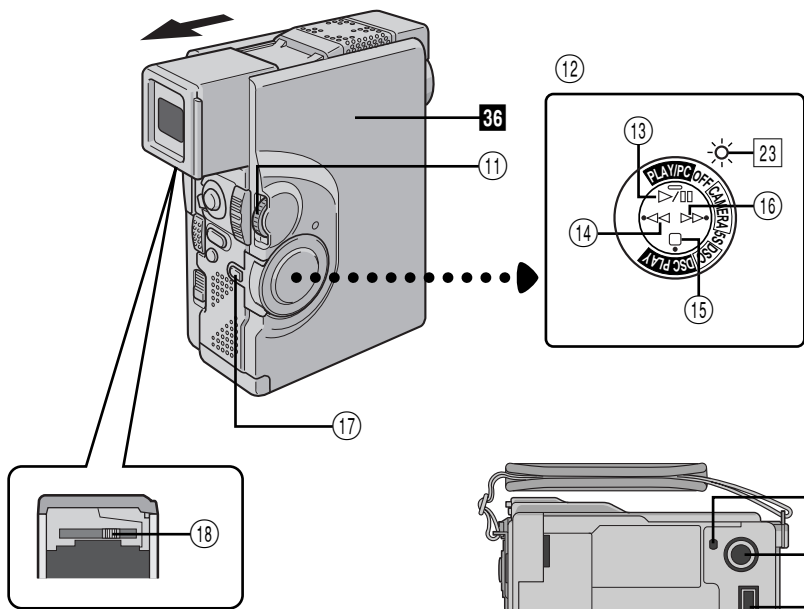
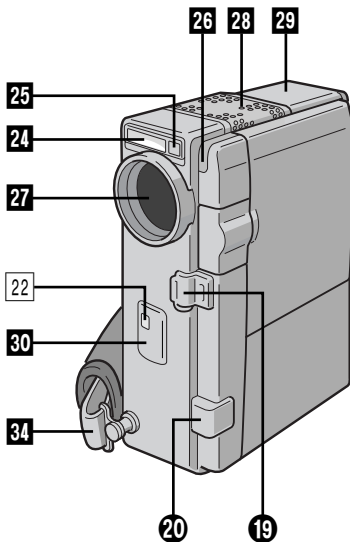
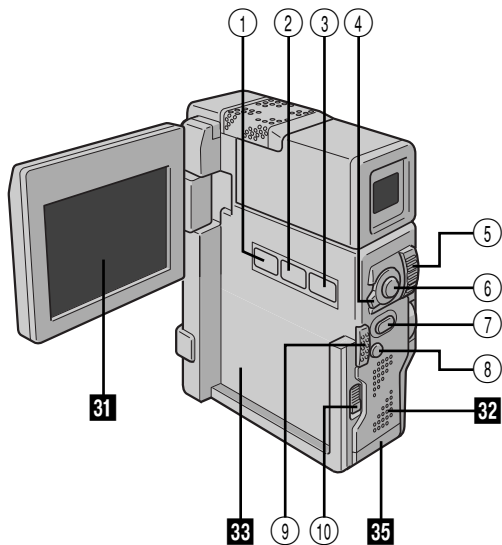













*** Auto Shut Off:**

If 5 minutes elapse in the Record-Standby mode or in the Pause mode, the camcorder's power shuts off automatically to conserve energy.

- ② PC Connector [DIGITAL STILL] ☞ pg. 72
- ③ Edit Connector [EDIT] ☞ pg. 85
Connect the editing cable when performing Random Assemble Editing (☞ pg. 84 – 89).
- ④ Stud..... ☞ pg. 70
- ⑤ Screw ☞ pg. 70
- ⑥ Multi Connector
The Docking Station can be connected with this camcorder through this connector. Never touch it with your hand or hit it with a hard object; if the pins are damaged, the connectors will become unusable due to contact failure.
- ⑦ S-Video Output Connector
[S OUT] ☞ pg. 70, 85
- ⑧ Video Output Connector
[VIDEO] ☞ pg. 70, 85
- ⑨ Audio Output Connector
[AUDIO L/R] ☞ pg. 70, 85
- ⑩ External Stereo Microphone Input
Connector [MIC] ☞ pg. 90
- ⑪ Screw Knob ☞ pg. 70
To attach the camcorder, tighten this clockwise.







Controls



- ① Snapshot Mode Button
[SNAPSHOT MODE]  pg. 22, 30
- ② Multi Screen Button
[MULTI SCREEN]  pg. 40
- ③ Title/Frame [TITLE] Button  pg. 69
- ④ Operation Switch [**A** , **M**]  pg. 17
- ⑤ • Power Zoom Lever [T/W]  pg. 24
 - Speaker/Headphone Volume Control [VOL.]  pg. 52
- ⑥ • Recording Start/Stop Button
[START/STOP]  pg. 18
 - Transfer Button [TRANS]  pg. 79
- ⑦ SNAPSHOT/PHOTO Button  pg. 22, 30
- ⑧ Back Light Button [BACK LIGHT]  pg. 48
- ⑨ OPEN/EJECT Switch  pg. 12
- ⑩ Battery Release Switch
[BATT. RELEASE]  pg. 9
- ⑪ • MENU/SET Dial [+ , - , PUSH]  pg. 11, 34
 - LCD Monitor/Viewfinder Brightness Control  pg. 21
- ⑫ Power Switch  pg. 17
- ⑬ Play/Pause Button [▶/||]  pg. 52
- ⑭ Rewind Button [◀◀]  pg. 52
- ⑮ Stop Button [■]  pg. 52
- ⑯ Fast-Forward Button [▶▶]  pg. 52
- ⑰ Lock Button  pg. 17
- ⑱ Diopter Adjustment Control  pg. 10

Connectors















The connectors ⑱ to ㉑ are located beneath the cover.

- ⑲ Digital Video Connector
[DV IN/OUT] (i.link*)  pg. 72, 73, 75
 - *i.Link refers to the IEEE1394-1995 industry specification and extensions thereof. The  logo is used for products compliant with the i.Link standard.
- ⑳ • Audio/Video Output Connector
[AV OUT]  pg. 70
 - Headphones Connector [Ω]  pg. 90
- ㉑ Multi Connector
When attached to the Docking Station, this part is connected.

Indicators

- ㉒ Tally Lamp  pg. 18
- ㉓ Power Lamp  pg. 18

Other Parts

- ㉔ Flash  pg. 32
- ㉕ Flash Sensor  pg. 32
 - Be careful not to cover this area, as it contains a sensor required by the flash.
- ㉖ Camera Sensor
Be careful not to cover this area; a sensor necessary for shooting is built-in here.
- ㉗ Lens Cover
Opens when the viewfinder is pulled out or the LCD monitor is opened fully.
- ㉘ Stereo Microphone  pg. 90
- ㉙ Viewfinder  pg. 10
- ㉚ • Remote sensor  pg. 80
 - Infrared Transmitter/Receiver  pg. 78
- ㉛ LCD Monitor  pg. 21
- ㉜ Speaker  pg. 52
- ㉝ Battery Pack Mount  pg. 9
- ㉞ Grip Strap  pg. 10
- ㉟ Card Cover  pg. 14
- ㊱ Cassette Cover  pg. 12
- ㊲ Stud Hole  pg. 70
- ㊳ Tripod Mounting Socket  pg. 16, 70

LCD Monitor/Viewfinder Indications During Video Recording Only

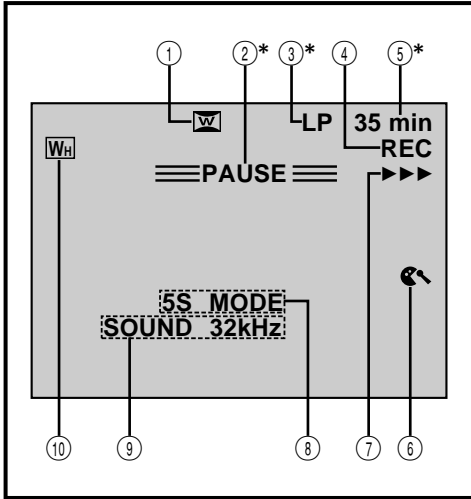

No.	Function
①	Appears when in the Squeeze or Cinema mode. (☞ pg. 37)
②*	Appears when in the Record-Standby mode. (☞ pg. 18)
③*	Displays the recording mode (SP or LP). (☞ pg. 13)
④	Appears during recording. (☞ pg. 18)
⑤*	Displays the tape remaining time. (☞ pg. 19)
⑥	Appears when the wind cut mode is engaged to cut down on noise created by wind. (☞ pg. 39)
⑦	Appears while the tape is running. (☞ pg. 18)
⑧	5S MODE/5SD MODE/ANIM. MODE: Displays the 5 second recording mode, Dissolve during 5 second recording mode or Animation recording mode. (☞ pg. 28, 39)
⑨	Displays the sound mode for approx. 5 seconds after turning on the camcorder. (☞ pg. 39)
⑩	Displays the selected Fade/Wipe effect. (☞ pg. 41)

* : Setting "INDICATION" to "OFF" in the Date/Time Menu lets you remove indications marked with * from the screen (☞ pg. 27).

LCD Monitor/Viewfinder Indications During D.S.C. Recording Only

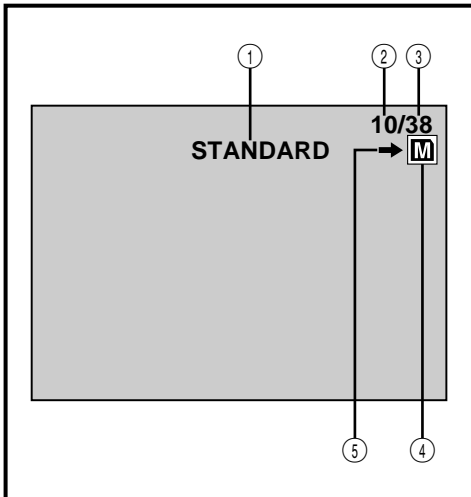

No.	Function
①	Displays the Picture Quality mode of the stored image. There are 3 modes available: FINE, STANDARD and ECONOMY (in order of quality). (☞ pg. 15, 22)
②	Displays the number of images that have already been shot. (☞ pg. 22)
③	Displays the total number of shots that can be stored, including those already taken. (☞ pg. 22)
④	<ul style="list-style-type: none"> • Appears when a MultiMediaCard is loaded. • Blinks when a MultiMediaCard is not loaded. (☞ pg. 22)
⑤	Appears and blinks during shooting. (☞ pg. 22)

LCD Monitor/Viewfinder Indications During Both Video And D.S.C. Recording

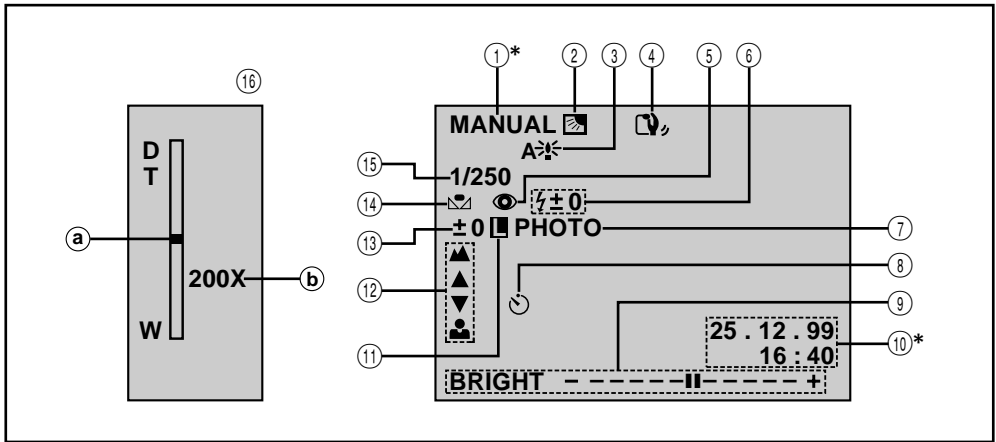

No.	Function	
①*	Displays the operation mode position.	(☞ pg. 17)
②	Appears when backlight compensation is used.	(☞ pg. 48)
③	Appears when Auto Slow Shutter is engaged ("GAIN UP" is set to "AUTO").	(☞ pg. 37)
④	Appears when Digital Image Stabilizer ("DIS") is engaged.	(☞ pg. 37)
⑤	Appears when "FLASH" is set to "AUTO" in the Mode Menu.	(☞ pg. 32)
⑥	Appears when the flash is ready. A number appears next to the indication after adjusting the brightness of the flash.	(☞ pg. 32, 33)
⑦	Appears when taking a Snapshot.	(☞ pg. 22, 30)
⑧	Appears during Self-Timer recording.	(☞ pg. 29)
⑨	Displays the brightness of the LCD monitor or the viewfinder.	(☞ pg. 21)
⑩*	Displays the date/time.	(☞ pg. 11, 38)
⑪	Appears when the iris is locked.	(☞ pg. 49)
⑫	Appears when the focus is adjusted manually.	(☞ pg. 47)
⑬	Appears when the exposure is adjusted.	(☞ pg. 48)
⑭	Appears when the white balance is adjusted.	(☞ pg. 51)
⑮	Displays the selected Program AE with special effects.	(☞ pg. 44)
⑯	Appears during zooming. Ⓐ Zoom level indicator Ⓑ Approximate zoom ratio	(☞ pg. 24)

* : Setting "INDICATION" to "OFF" in the Date/Time Menu lets you remove indications marked with * from the screen (☞ pg. 27).

LCD Monitor/Viewfinder Indications During Video Playback

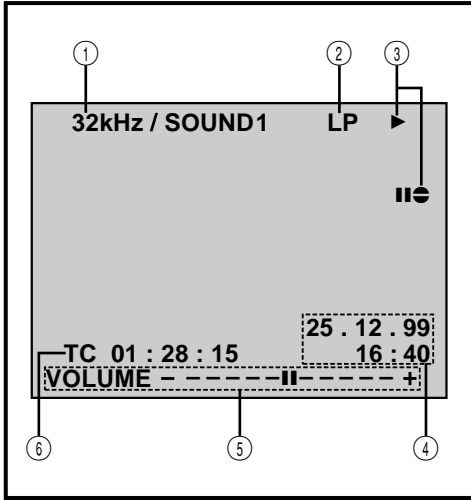





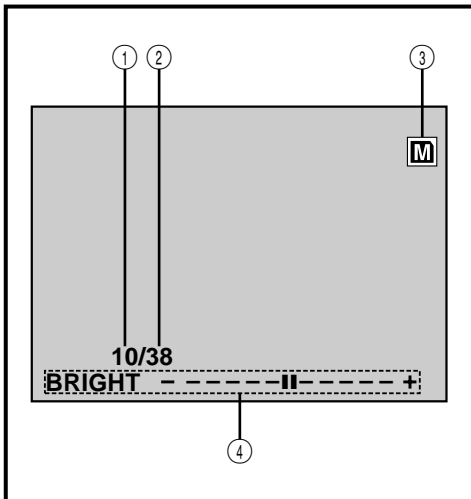

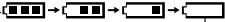

No.	Function
①	Displays the sound mode. (☞ pg. 55)
②	Displays the tape speed.
③	Appears while a tape is running. ▶ : Playback ▶▶ : Fast-Forward/Shuttle search ◀◀ : Rewind/Shuttle search : Pause ▶ : Forward slow-motion ◀ : Reverse slow-motion ● : Audio Dubbing ● : Audio Dubbing Pause
④	Displays the date/time. (☞ pg. 55)
⑤	BRIGHT: Displays the brightness of the LCD monitor or the viewfinder. (☞ pg. 21) VOLUME: Displays the speaker or headphone volume. (☞ pg. 52)
⑥	Displays the time code. (☞ pg. 55)

LCD Monitor/Viewfinder Indications During D.S.C. Playback









No.	Function
①	Displays the index number of the image file. (☞ pg. 56)
②	Displays the total number of stored images. (☞ pg. 56)
③	• Appears when a MultiMediaCard is loaded. • Blinks when a MultiMediaCard is not loaded.
④	Displays the brightness of the LCD monitor or the viewfinder. (☞ pg. 21)







Warning Indications

Indications	Function
	<p>Displays the battery remaining power.</p> <p>Remaining power level: high  →  →  → </p> <p>Remaining power level: exhausted </p> <p>As the battery power comes close to nil, the battery indicator  blinks. When the battery power is exhausted, power turns off automatically.</p>
	<p>Appears when no tape is loaded, or when the erase protection tab is set to "SAVE". (☞ pg. 12)</p>
	<p>Appears if dirt is detected on the heads during recording. (☞ pg. 108)</p>
	<p>Appears if condensation occurs. When this indication is displayed, the camcorder turns off automatically.</p>
<p>TAPE!</p>	<p>Appears for approx. 10 seconds when the Power Switch is set to "CAMERA" or "5S" when a tape is not loaded.</p>
<p>TAPE END</p>	<p>Appears when the tape ends during recording or playback. (☞ pg. 19)</p>
<p>SET DATE/TIME!</p>	<ul style="list-style-type: none"> • Appears when the date/time is not set. (☞ pg. 11) • Appears when the clock (lithium) battery is discharged and the previously set date/time is erased. (☞ pg. 11)
<p>ERROR! REFER MANUAL</p>	<p>Appears when Audio Dubbing is unavailable. (☞ pg. 90)</p>
<p>MEMORY IS FULL</p>	<p>Appears when the MultiMediaCard's memory is full and shooting is not possible.</p>
<p>MEMORY CARD!</p>	<p>Displayed for approx. 10 seconds when the Power Switch is set to "DSC" or "DSC PLAY" when a MultiMediaCard is not loaded.</p>
<p>PLEASE INITIALIZE</p>	<p>Appears when there is a problem with a MultiMediaCard and its memory is corrupt. Initialize the MultiMediaCard. (☞ pg. 91)</p>
<p>NO STORED IMAGE</p>	<p>Appears when the Power Switch set to "DSC PLAY" when there are no images stored in the MultiMediaCard.</p>
<p>E01 — E06</p>	<p>The error indications (E01 — E06) show what type of malfunction has occurred. When an error indication appears, the camcorder turns off automatically. Remove the power supply (battery, etc.) and wait a few minutes for the indication to clear. When it does, you can resume using the camcorder. If the indication remains, consult your nearest JVC dealer. (☞ pg. 97)</p>





A

- AC Power Adapter/Charger  pg. 8, 9
- Animation  pg. 39
- Audio Dubbing  pg. 90
- Auto Focus  pg. 46
- Auto Playback  pg. 56
- Auto Shut off  pg. 19, 52, 99













B

- Back Light Compensation  pg. 48
- Battery Low  pg. 105
- Battery Pack  pg. 8, 9, 107
- Beep/Tally  pg. 39
- Brighten The LCD Monitor  pg. 21
- Built-in Clock's Lithium Battery  pg. 11



C

- Charge The Battery Pack  pg. 8
- Cinema  pg. 37
- Classic Film  pg. 45
- Clean The Camcorder  pg. 98
- Connections  pg. 9, 70 – 75, 85

D

- Darken The LCD Monitor  pg. 21
- Date/Time Display  pg. 26, 55
- Date/Time Settings  pg. 11
- Deleting Images  pg. 64
- Deleting Titles/Frames  pg. 66
- Demonstration Mode  pg. 39
- Digital Dubbing  pg. 75
- Digital Zoom  pg. 24, 37
- DIS (Digital Image Stabiliser)  pg. 37
- Dioptr Adjustment  pg. 10
- Dissolve During 5-second Recording Mode ...  pg. 28
- Dubbing  pg. 74 – 79

E

- Erase Protection  pg. 12
- Exposure Control  pg. 48





F

- Fade-In/Out  pg. 41
- Fast-Forward The Tape  pg. 52
- 5-second recording mode  pg. 28
- Flash  pg. 32, 33

G

- Gain Up  pg. 37
- Grip Adjustment  pg. 10



I

- Index Playback  pg. 59
- Interface Shooting  pg. 21
- Iris  pg. 49
- Iris Lock  pg. 49
- IrTran-P  pg. 78







J

- Journalistic Shooting  pg. 21

L

- LCD monitor/Viewfinder Indications  pg. 102 – 104
- Load A Tape  pg. 12









M

- Manual Focus  pg. 47
- Mode Menu  pg. 37
- Monotone  pg. 45
- Motor Drive Mode  pg. 30
- Multi-Image Screen  pg. 60
- MultiMediaCard  pg. 14, 107
- Multi Screen Mode  pg. 40









O

- Operation Switch Position  pg. 17

















P

- Picture Quality Mode  pg. 15
- Picture Wipe/Dissolve  pg. 42
- Playback Menu  pg. 54
- Playback Special Effects  pg. 83
- Playback Zoom  pg. 82
- Power Switch Position  pg. 17
- Program AE With Special Effects  pg. 44
- Protecting Images  pg. 62
- Provided Accessories  pg. 4





R

- Random Assemble Editing  pg. 84 – 89
- Record-Standby  pg. 18
- Recording Format  pg. 5
- Recording Menu  pg. 36
- Recording Mode  pg. 13
- Red-Eye Reduction  pg. 32
- Remote Control  pg. 80
- Rewind The Tape  pg. 52

S

- Self-Recording  pg. 21
- Self-Timer  pg. 29
- Sepia  pg. 45
- Set Remote Control/VCR Code  pg. 84
- Shuttle Search  pg. 53
- Shutter Speed  pg. 45
- Slide Show  pg. 57
- Slow-Motion Playback  pg. 82
- Slow Shutter  pg. 45
- Snapshot Mode  pg. 22, 30
- Sound Mode  pg. 39, 55
- Specifications  pg. 109, 110
- Squeeze  pg. 37
- Still Playback  pg. 53
- Strobe  pg. 45
- System Menu  pg. 39

T

- Tele Macro  pg. 39
- Time Code  pg. 5, 25
- Title/Frame  pg. 68
- Tripod Mounting  pg. 16
- Twilight  pg. 45





U

- Unload A Tape  pg. 12

V

- Video Echo  pg. 45

W

- White Balance  pg. 50, 51
- Wide Mode  pg. 37
- Wind Cut  pg. 39
- Wipe In/Out  pg. 41

Z

- Zooming  pg. 24

Battery Packs

The supplied battery pack is a lithium-ion battery. Before using the supplied battery pack or an optional battery pack, be sure to read the following cautions:

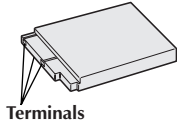

- 1. To avoid hazard . . .**
 - ... do not burn.
 - ... do not short-circuit the terminals.
 - ... do not modify or disassemble.
 - ... do not expose the battery to temperatures exceeding 60°C (140°F), as this may cause the battery to overheat, explode or catch fire.
 - ... use only specified chargers.
- 2. To prevent damage and prolong service life . . .**
 - ... do not subject to unnecessary shock.
 - ... charge in an environment where temperatures are within the tolerances shown in the chart below. This is a chemical reaction type battery—cooler temperatures impede chemical reaction, while warmer temperatures can prevent complete charging.
 - ... store in a cool, dry place. Extended exposure to high temperatures will increase natural discharge and shorten service life.
 - ... fully charge and then fully discharge the battery every 6 months when storing the battery pack over a long period time.
 - ... remove from charger or powered unit when not in use, as some machines use current even when switched off.

NOTES:

- *It is normal for the battery pack to be warm after charging, or after use.*
- Temperature Range Specifications**
 - Charging 10°C to 35°C (50°F to 95°F)
 - Operation 0°C to 40°C (32°F to 104°F)
 - Storage -10°C to 30°C (-14°F to 86°F)
- *Recharging time is based on room temperature of 20°C (68°F).*
- *The lower the temperature, the longer recharging takes.*

Cassettes

To properly use and store your cassettes, be sure to read the following cautions:

- 1. During use . . .**
 - ... make sure the cassette bears the Mini DV mark.
 - ... be aware that recording onto prerecorded tapes automatically erases the previously recorded video and audio signals.
 - ... make sure the cassette is positioned properly when inserting.
 - ... do not load and unload the cassette repeatedly without allowing the tape to run at all. This slackens the tape and can result in damage.
 - ... do not open the front tape cover. This exposes the tape to fingerprints and dust.
- 2. Store cassettes . . .**
 - ... away from heaters or other heat sources.
 - ... out of direct sunlight.
 - ... where they won't be subject to unnecessary shock or vibration.
 - ... where they won't be exposed to strong magnetic fields (such as those generated by motors, transformers or magnets).
 - ... vertically, in their original cases.

MultiMediaCards

To properly use and store your MultiMediaCards, be sure to read the following cautions:

- 1. During use . . .**
 - ... make sure the MultiMediaCard bears the MultiMediaCard mark.
 - ... make sure the MultiMediaCard is positioned properly when inserting.
- 2. While the MultiMediaCard is being accessed (during recording, playback, deletion, initialisation, etc.) . . .**
 - ... never unload the MultiMediaCard and never turn off the camcorder.
- 3. Store MultiMediaCards . . .**
 - ... away from heaters or other heat sources.
 - ... out of direct sunlight.
 - ... where they won't be subject to unnecessary shock or vibration.
 - ... where they won't be exposed to strong magnetic fields (such as those generated by motors, transformers or magnets).

LCD Monitor

- 1. To prevent damage to the LCD monitor, DO NOT . . .**
 - ... push it strongly or apply any shocks.
 - ... place the camcorder with the LCD monitor on the bottom.
- 2. To prolong service life . . .**
 - ... avoid rubbing it with coarse cloth.
- 3. Be aware of the following phenomena for LCD monitor use.**
 - These are not malfunctions:**
 - While using the camcorder, the surface around the LCD monitor and/or the back of the LCD monitor may heat up.
 - If you leave power on for a long time, the surface around the LCD monitor becomes hot.

Main Unit

- 1. For safety, DO NOT . . .**
 - ... open the camcorder's chassis.
 - ... disassemble or modify the unit.
 - ... short-circuit the terminals of the battery pack. Keep it away from metallic objects when not in use.
 - ... allow inflammables, water or metallic objects to enter the unit.
 - ... remove the battery pack or disconnect the power supply while the power is on.
 - ... leave the battery pack attached when the camcorder is not in use.
- 2. Avoid using the unit . . .**
 - ... in places subject to excessive humidity or dust.
 - ... in places subject to soot or steam such as near a cooking stove.
 - ... in places subject to excessive shock or vibration.
 - ... near a television set.
 - ... near appliances generating strong magnetic or electric fields (speakers, broadcasting antennas, etc.).

.... in places subject to extremely high (over 40°C or 104°F) or extremely low (under 0°C or 32°F) temperatures.

3. DO NOT leave the unit . . .

- in places of over 50°C (122°F).
- in places where humidity is extremely low (below 35%) or extremely high (above 80%).
- in direct sunlight.
- in a closed car in summer.
- near a heater.

4. To protect the unit, DO NOT . . .

- allow it to become wet.
- drop the unit or strike it against hard objects.
- subject it to shock or excessive vibration during transportation.
- keep the lens directed at extremely bright objects for long periods.
- expose the lens to direct sunlight.
- carry it by holding the LCD monitor or the viewfinder.
- swing it excessively when using the hand strap or the grip.
- swing the soft camera case excessively when the camcorder is inside it.

5. Dirty heads can cause the following problems:

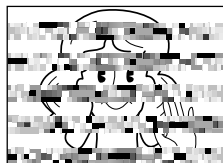

- No picture during playback.
- Blocks of noise appear during playback.
- During recording, the Head Clog Warning indicator "⊗" appears.

In such cases, use the optional Cleaning Cassette. Insert it and play back. If the cassette is used more than once consecutively, damage to the video heads may result. After the camcorder plays back for about 20 seconds, it stops automatically. Also refer to the Cleaning Cassette's instructions.

If, after using the Cleaning Cassette, the problems still exist, consult your nearest JVC dealer. Mechanical moving parts used to move the video heads and video tape tend to become dirty and worn out over time. In order to maintain a clear picture at all times, periodic check-ups are recommended after using the unit for about 1,000 hours. For periodic check-ups please consult your nearest JVC dealer.

How To Handle A CD-ROM

- Take care not to soil or scratch the mirror surface (opposite to the printed surface). Do not write anything or put a sticker on either the front or back surface. If the CD-ROM gets dirty, gently wipe it with a soft cloth outward from the centre hole using a circular motion.
- Do not use conventional disc cleaners or cleaning spray.
- Do not bend the CD-ROM or touch its mirror surface.
- Do not store your CD-ROM in a dusty, hot or humid environment. Keep it away from direct sunlight.

About moisture condensation . . .

- You have observed that pouring a cold liquid into a glass will cause drops of water to form on the glass' outer surface. This same phenomenon occurs on the head drum of a camcorder when it is moved from a cool place to a warm place, after heating a cold room, under extremely humid conditions or in a place directly subjected to the cool air from an air conditioner.
- Moisture on the head drum can cause severe damage to the video tape, and can lead to internal damage to the camcorder itself.



Serious malfunctioning

If malfunctioning occurs, stop using the unit immediately and consult your local JVC dealer.

The camcorder is a microcomputer-controlled device. External noise and interference (from a TV, a radio, etc.) might prevent it from functioning properly. In such cases, first disconnect its power supply unit (battery pack, AC Power Adapter/Battery Charger, etc.) and wait a few minutes and then re-connect it and proceed as usual from the beginning.

Camcorder

For General

Power supply	: DC 6.3 V  (Using the AC Power Adapter/Charger) DC 7.2 V  (Using battery pack)
Power consumption	
LCD monitor off, viewfinder on	: Approx. 4.5 W
LCD monitor on, viewfinder off	: Approx. 5.4 W
Dimensions	: 48 (W) x 119 (H) x 89 (D) mm (with the LCD monitor closed and the viewfinder pushed back in)
Weight	: Approx. 440 g (without grip strap, cassette, MultiMediaCard and battery) Approx. 525 g (incl. grip strap, cassette, MultiMediaCard and battery)
Operating temperature	: 0°C to 40°C
Operating humidity	: 35% to 80%
Storage temperature	: -20°C to 50°C
Pickup	: 1/4" CCD
Lens	: F 1.8, f = 3.6 to 36 mm, 10:1 Power Zoom Lens
Filter diameter	: ø27 mm
LCD monitor	: 2.5" diagonally measured, LCD panel/TFT active matrix system
Viewfinder	: Electronic viewfinder with 0.55" colour LCD
Speaker	: Monaural

For Digital Video Camera

Format	: DV Format (SD mode)
Signal format	: PAL Standard
Video signal recording format	: Digital Component Recording
Cassette	: Mini DV Cassette
Tape Speed	: SP: 18.8 mm/s LP: 12.5 mm/s
Maximum recording time	: SP: 60 min. LP: 90 min. (using M-DV60ME cassette)

For Digital Still Camera

Storage media	: MultiMediaCard
Compression system	: JPEG (compatible)
Picture quality	: 3 modes (FINE/STANDARD/ECONOMY)
Number of storable images (with the provided MultiMediaCard [4 MB])	
FINE	: Approximately 30
STANDARD	: Approximately 50
ECONOMY	: Approximately 100
Infrared transmitter/receiver	: IrDA Ver. 1.0 (IrTran-P compatible)

For Connectors

Video output	: 1 Vp-p, 75 Ω unbalanced, analogue output (via AV OUT connector)
Audio output	: -8 dBs, 1 kΩ analogue output, stereo (via AV OUT connector)
Headphone output	: ø3.5 mm, stereo (via AV OUT connector)
DV input/output	: 4-pin, IEEE1394 compliant

Specifications shown are for SP mode unless otherwise indicated. E & O.E. Design and specifications subject to change without notice.

AC Power Adapter/Charger AA-V50A or AA-V50SH

Power requirement	: AC 110 V to 240 V~, 50/60 Hz
Power consumption	: 20 W
Output	
Charge	: DC 7.2 V $\overline{\text{---}}$, 0.63 A
VTR	: DC 6.3 V $\overline{\text{---}}$, 1.8 A
Dimensions	: 122 (W) x 39 (H) x 92 (D) mm
Weight	
AA-V50A	: Approx. 310 g
AA-V50SH	: Approx. 380 g

Docking Station CU-V501E**For General**

Dimensions	: 115 mm (W) x 31 mm (H) x 55 mm (D)
Weight	: Approx. 90 g

For Connectors

S-Video	: Y: 1V _{p-p} , 75 Ω , analogue output C: 0.29 V _{p-p} , 75 Ω , analogue output
Video	: 1V _{p-p} , 75 Ω , analogue output
Audio	: -8 dBs, 1 k Ω , analogue output
JLIP	: \varnothing 3.5 mm, 4-pole, mini-head jack (compatible with RC-5325 plug)
Editing	: \varnothing 3.5 mm, 2-pole
PC	: \varnothing 2.5 mm, 3-pole
External microphone input	: -68 dBs, high impedance unbalanced with \varnothing 3.5 mm (stereo)

E & O.E. Design and specifications subject to change without notice.

EN

GR-DVXX70

JVC[®]
VICTOR COMPANY OF JAPAN, LIMITED

©Registered Trademark owned by VICTOR COMPANY OF JAPAN, LTD.
COPYRIGHT© 1999 VICTOR COMPANY OF JAPAN, LTD.

SH/A  Printed in Japan
0599AYV*UN*SN